

Another  
Innovative  
Product  
from  
A.Y. McDonald  
Mfg. Co.



# AutoDRIVE

## VARIABLE FREQUENCY DRIVE

115V / 230V | Single Phase Output  
1/3 HP to 2 HP  
2 Wire & 3 Wire Motors

230V | Three Phase Output  
2 HP, 3 HP, 5 HP



Includes Models:

- SD1-2HP2
- SD1-2HP2PS
- SD3-2HP2
- SD3-3HP2
- SD3-5HP2



*American Made & Built To Last*

## SAFETY MESSAGES AND WARNINGS

To ensure safe and reliable operation of the AutoDRIVE VFDs, it is important to carefully read this manual and to observe all warning labels attached to the unit before installing. Please follow all instructions exactly and keep this manual with the unit for quick and easy reference.

### Definitions of Warning Signs and Symbols

 **CAUTION:** Indicates a potentially hazardous situation that could result in injury or damage to the product.

 **WARNING:** Indicates a potentially hazardous situation that could result in serious injury or death.

 **HIGH VOLTAGE:** The voltage associated with the procedures referenced could result in serious injury or death. Use caution and follow instructions carefully.

### READ THESE WARNINGS BEFORE INSTALLING OR OPERATING EQUIPMENT!

 **WARNING:** Risk of electric shock. More than one disconnect switch may be required to de-energize the equipment before servicing.

 **WARNING:** Risk of electric shock. De-energize the unit by disconnecting all incoming sources of power, then wait 10 minutes for internal charges to dissipate before servicing the equipment.

 **HIGH VOLTAGE:** This equipment is connected to line voltages that can create a potentially hazardous situation. Electric shock could result in serious injury or death. This device should be installed only by trained, licensed, and qualified personnel. Follow instructions carefully and observe all warnings.

 **WARNING::** This equipment should be installed and serviced by qualified personnel familiar with the type of equipment and experienced in working with dangerous voltages.

 **WARNING:** Installation of this equipment must comply with the National Electrical Code (NEC) and all applicable local codes. Failure to observe and comply with these codes could result in risk of electric shock, fire, or damage to the equipment.

 **CAUTION:** Circuit breakers, fuses, proper ground circuits, and other safety equipment and their proper installation are not provided by A.Y. McDonald Mfg. Co., and are the responsibility of the end user.

 **CAUTION:** Failure to maintain adequate clearance may lead to overheating of the unit and cause damage or fire.

 **WARNING:** Input power connections should be made by a qualified electrician into circuit with adequate voltage and current carrying capacity for the model. Branch circuit protection to the unit should be provided by appropriately sized fuses or a 2-pole circuit breaker.

 **CAUTION:** Use 600 V vinyl-sheathed wire or equivalent. The voltage drop of the leads needs to be considered in determining wire size. Voltage drop is dependent on wire length and gauge. Use only copper conductors.

 **CAUTION:** Wires fastened to the terminal blocks shall be secured by tightening the terminal screws to a torque value listed in **Table 4**, pg. 9.

 **CAUTION:** The input wire gauge must be sized to accommodate the single-phase input current, which will be significantly larger than the output current to the load.

**CAUTION:** The maximum wire gauge for the input terminals is listed in **Table 4**, pg. 9.



**CAUTION:** Never allow bare wire to contact metal surfaces.



**CAUTION:** Never connect AC main power to the output terminals Red (R), Blk/Yel (Y), and Blk (B).



**WARNING:** Under certain conditions, the motor load may automatically restart after a trip has stopped it. Make sure power to the drive has been disconnected before approaching or servicing the equipment. Otherwise, serious injury may occur.

## TABLE OF CONTENTS

|  |           |
|--|-----------|
| <b>1 INTRODUCTION</b> .....  | <b>5</b>  |
| <b>2 RATINGS</b> .....   | <b>6</b>  |
| <b>3 INSTALLATION</b> .....  | <b>8</b>  |
| 3.1 MOUNTING YOUR NEW AutoDRIVE VFD .....                            | 8         |
| 3.2 PROPER VENTILATION .....   | 8         |
| 3.3 SOURCE BRANCH CIRCUIT PROTECTION.....                            | 8         |
| 3.4 GROUNDING.....   | 9         |
| 3.5 WIRE SIZING .....  | 9         |
| 3.6 CONNECTING THE LOAD.....   | 9         |
| 3.7 CONNECTING TO FIELD WIRING TERMINALS .....                       | 10        |
| 3.8 ROUTING POWER CABLES .....                                       | 10        |
| 3.9 CONTROL WIRING .....   | 11        |
| <b>4 USING THE KEYPAD AND DISPLAY</b> .....                          | <b>16</b> |
| 4.1 DISPLAY MODES.....   | 16        |
| 4.2 PASSWORD PROTECTING THE KEYPAD .....                             | 16        |
| 4.3 KEYPAD DISPLAY MESSAGES.....                                     | 17        |
| 4.4 KEYPAD MAIN MENU ITEMS.....                                      | 17        |
| 4.5 CHANGE PARAMETER VALUES.....                                     | 18        |
| 4.6 READ MEASURED VALUES.....  | 19        |
| 4.7 READ TIMERS .....  | 21        |
| 4.8 CLEAR MEMORY .....   | 21        |
| 4.9 RESTART LOG.....   | 22        |
| <b>5 ADJUSTABLE PARAMETERS</b> .....                                 | <b>23</b> |
| 5.1 CHANGING PARAMETER VALUES .....                                  | 23        |
| 5.2 RESTORE DEFAULT PARAMETER SETTINGS.....                          | 23        |
| 5.3 AUTO RESTARTS.....   | 24        |
| 5.4 MENU STRUCTURE OVERVIEW .....                                    | 25        |
| <b>6 OPERATION</b> .....   | <b>33</b> |
| 6.1 COMMISSIONING THE UNIT .....                                     | 33        |
| 6.2 GROUND FAULT DETECTION .....                                     | 35        |
| 6.3 DRY WELL/DEADHEAD PROTECTION & LOW PRODUCTION WELL CONTROL ..... | 37        |
| 6.4 MOTOR OVERLOAD PROTECTION.....                                   | 37        |
| 6.5 SYSTEM CONFIGURATION.....  | 38        |
| 6.6 START-UP AND SHUT-DOWN RAMP TIMES .....                          | 38        |
| <b>7 CONSTANT PRESSURE SYSTEMS</b> .....                             | <b>39</b> |
| 7.1 CONTROL PRINCIPLES OF CONSTANT PRESSURE SYSTEMS.....             | 39        |
| 7.2 DIGITAL PRESSURE SWITCH .....                                    | 41        |
| 7.3 DIGITAL CONSTANT PRESSURE SYSTEMS .....                          | 42        |
| 7.4 CONSTANT PRESSURE SETUP .....                                    | 44        |
| 7.5 ANALOG CONSTANT PRESSURE SYSTEMS .....                           | 45        |
| 7.6 BASIC ANALOG CONSTANT PRESSURE INSTALLATION PROCEDURES .....     | 46        |
| 7.7 PRE-CHARGE MODE.....   | 47        |
| 7.8 TANK SIZING .....  | 48        |
| 7.9 TROUBLESHOOTING CONSTANT PRESSURE SYSTEMS .....                  | 49        |
| <b>8 TROUBLESHOOTING</b> .....                                       | <b>49</b> |
| 8.1 FAULT CODES.....   | 49        |
| 8.2 ROUTINE INSPECTION & MAINTENANCE .....                           | 53        |

## 1. Introduction

**AutoDRIVE** variable frequency drives (VFDs) are inverter-based devices that provide speed control for two-wire, three-wire single-phase, and three-phase AC motors. The drives offer advanced motor control features through an intuitive, easy-to-use interface.

The simplified block diagrams below demonstrate how the drive converts the incoming single-phase AC power to DC, then utilizes an inverter module to generate single-phase or three-phase variable voltage and frequency output to control the speed of the primary motor.

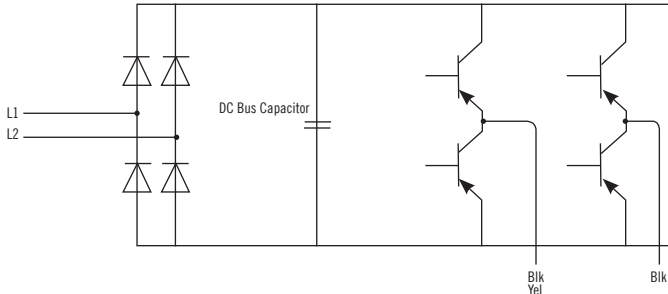

**Figure 1 – AutoDRIVE 2-Wire Block Diagram**

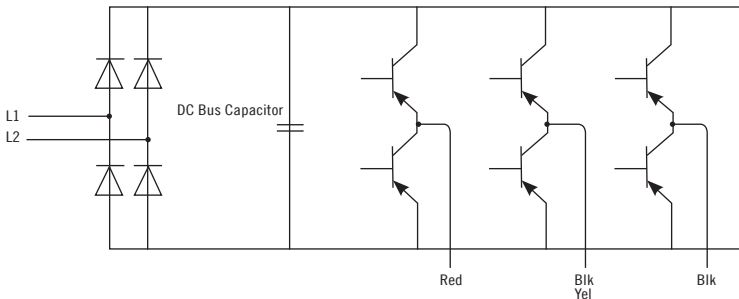

**Figure 2 – AutoDRIVE 3-Wire Block Diagram**

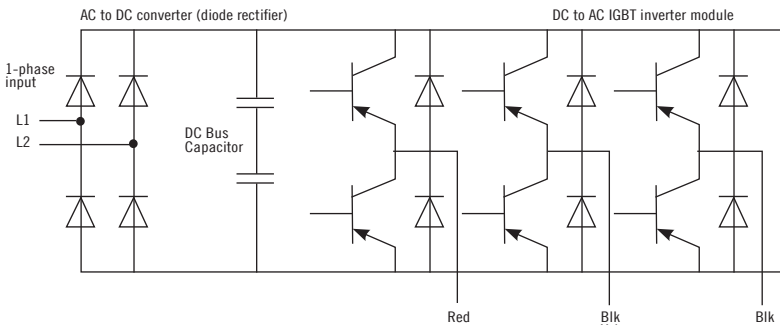

**Figure 3 – AutoDRIVE 3-Phase Block Diagram**

## 2. Ratings

### Product Specifications

**Table 1 – General Specifications**

| Auto Drive              | Single Phase                   | Three Phase   |
|-------------------------|--------------------------------|---|
| HP                      | 1/3 - 2                        | 2, 3, 5   |
| Motor Style             | Two-Wire or Three-Wire         | Three-Wire  |
| Nominal Input Voltage   | 115/230 VAC                    | 230 VAC   |
| Input Voltage Range     | 90 - 160 VAC   180 - 260 VAC   | 180 - 260 VAC   |
| Max. Input Current      | 28 A                           | 20 A, 30 A, 42 A  |
| Output Voltage          | Equal to Input                 | Equal to Input  |
| Max. Output Current     | 16 A                           | 11 A, 13 A, 22 A  |
| Enclosure Type          | NEMA 3R                        |   |
| Operating Temperature   | -20°C to 50°C (-4°F to 122°F)  | -20°C to 50°C (-4°F to 122°F)<br>-20°C to 40°C (-4°F to 104°F) - SD3-5HP3 |
| Storage Temperature     | -30°C to 60°C (-22°F to 140°F) |   |
| Dimensions (H x W x D)* | 13.25" x 9.00" x 5.75"         |   |
| Weight                  | 13 lbs                         |   |

\* Dimensions are approximate, detailed dimensions on next page.

AutoDRIVE VFDs can operate several types of systems, including:

- Simple ON/OFF motor control from the keypad or remote switches
- Digital constant pressure water systems
- Analog constant pressure water systems
- Analog speed potentiometer-controlled systems
- Pump Up or Pump Down water systems

The drive contains a wide range of settings and parameters allowing the user to easily configure the drive for many applications. Detailed information on setting System Configuration can be found in **Section 6.5**, on page 38.

## Enclosure Dimensions

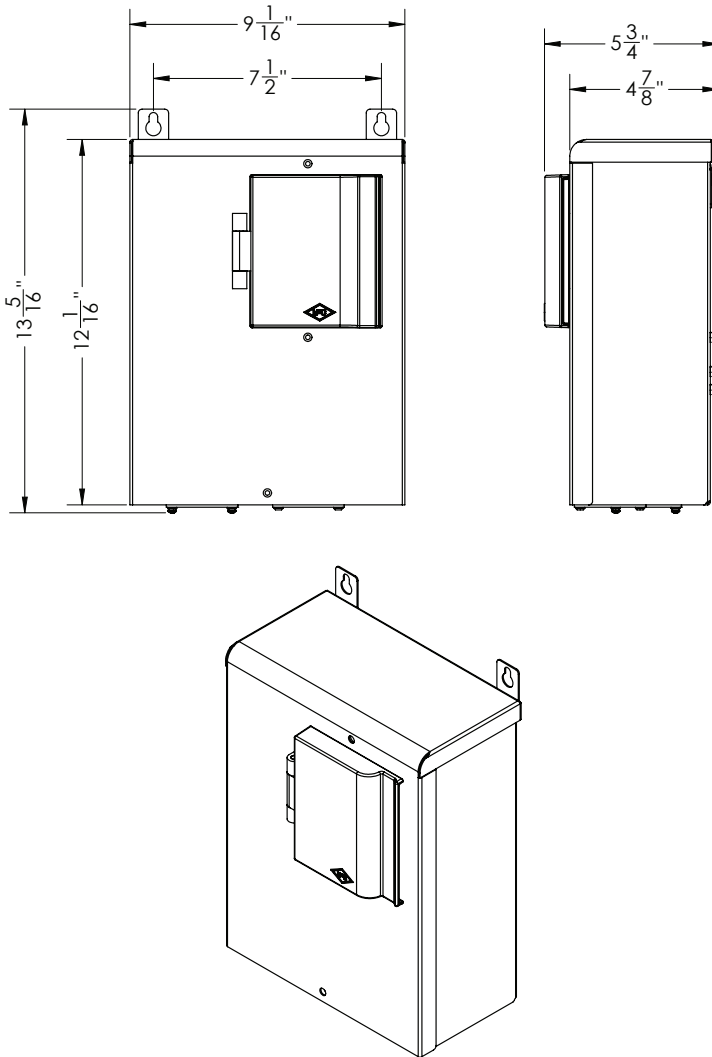

**Figure 4**— AutoDRIVE Enclosure Dimensions

## 3. Installations

### 3.1 Mounting Your New AutoDRIVE VFD

Proper installation of the unit is important to the performance and normal operating life of the unit. It should be installed in a location free from:

- Corrosive gases or liquids
- Excessive vibration
- Airborne metallic particles

Mount the unit to a solid, non-flammable surface capable of bearing the weight using the mounting brackets provided with the unit.

### 3.2 Proper Ventilation

To maintain air circulation for adequate cooling, minimum clearance around the unit must be maintained. Allow six inches on each side and top, and 18 inches below.

Ensure air intake and exhaust openings are not obstructed. If the unit is mounted in a small room, cabinet, or building, ensure there is adequate ventilation to provide sufficient cooling for the unit.

### 3.3 Source Branch Circuit Protection

Branch circuit protection must be installed in the circuit sourcing the drive. See **Table 2** for recommended circuit breaker sizing, which is based on 125% of the rated input current. Fuses may be used for circuit protection; consult local electrical code for proper sizing. Installation of a disconnection means within sight of the drive is recommended.

**Table 2 – Fuse/Breaker Recommendations**

| Fuse/Breaker Recommendations<br>Single Phase |               |              | Fuse/Breaker Recommendations<br>Three Phase |               |              |
|--|---------------|--------------|---|---------------|--------------|
| Motor HP                                     | Input Current | Fuse/Breaker | Motor HP                                    | Input Current | Fuse/Breaker |
| <b>115 V</b>                                 |               |              | <b>230 V</b>                                |               |              |
| 1/3  | 8 A           | 10 A         | 2   | 20 A          | 25 A         |
| 1/2  | 14 A          | 20 A         | 3   | 30 A          | 40 A         |
| 1  | 28 A          | 35 A         | 5   | 42 A          | 55 A         |
| <b>230 V</b>                                 |               |              |   |               |              |
| 1/2  | 6 A           | 10 A         |   |               |              |
| 3/4  | 9 A           | 15 A         |   |               |              |
| 1  | 14 A          | 20 A         |   |               |              |
| 1 1/2  | 18 A          | 25 A         |   |               |              |
| 2  | 28 A          | 35 A         |   |               |              |



### 3.4 Grounding

- Properly ground the drive according to local electrical code.
- Connect the ground lug to the branch circuit or service ground conductor.
- Resistance to ground measurement must be **25 Ohms or less**, according to the National Electric Code.

**Table 3** – Ground Wire Specifications

| Model     | Recommended Ground Wire Size |
|-----------|------------------------------|
| AutoDRIVE | 10 AWG                       |

### 3.5 Wiring Sizing

Wire size must comply with all NEC and local electrical code requirements. The voltage drop from the supply to the drive should be limited to 3% to ensure proper starting and operation of motor loads. Increase the wire gauge to provide adequate voltage to the load. Ensure the wire gauge is suitable for the terminal block, see **Table 4**.

Use the following formula to calculate line voltage drop.

$$V_{drop} = \text{wire resistance} \left( \frac{\Omega}{ft} \right) \times \text{wire length (ft)} \times \text{current}$$

See **Table 2**, pg. 8 for guidelines on fuse and breaker sizes. Installations must comply with all NEC and local electrical code requirements.

### 3.6 Connecting the Load

Overload, ground fault, and short circuit protection functions are built into the drive to protect the load side conductors and motor, as well as the drive itself, from faults.

**Table 4** – Input and Output Power Terminal Specifications

| Power Terminals:<br>Allowed Wire Range & Minimum Torque |             |
|---|-------------|
| Wire Size   | Torque      |
| 14 - 6 AWG  | 10.5 in-lbs |

## 3.7 Connecting to Field Wiring Terminals

For all line and load connections, see **Table 5** below.

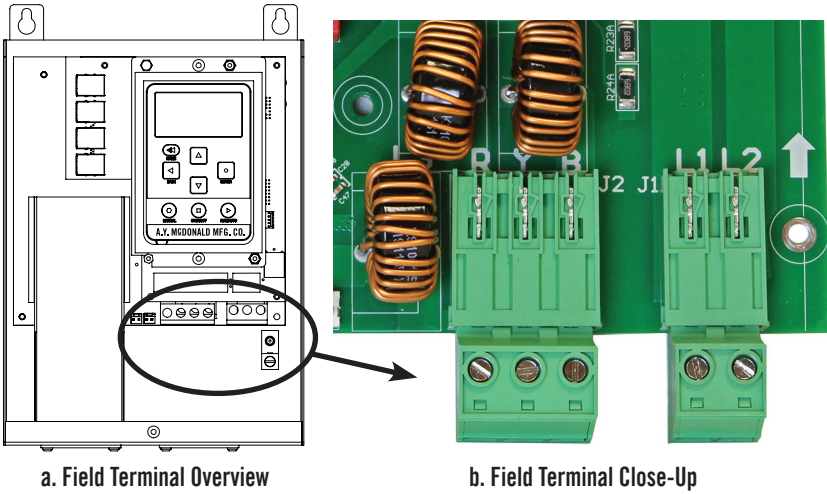

**Figure 5 – AutoDRIVE Field Wiring Terminals**

**Table 5 – Power Terminal Descriptions**

| Terminal Name                 | Description                       |
|-------------------------------|-----------------------------------|
| L1, L2                        | Input power terminals             |
| BLK (B), BLK/YEL (Y)          | Two-wire output power terminals   |
| RED (R), BLK/YEL (Y), BLK (B) | Three-wire output power terminals |
| RED                           | Auxiliary/Start/Run Winding       |
| BLK/YEL                       | Motor Winding Common              |
| BLK                           | Main Winding                      |
| GND                           | Earth ground                      |

## 3.8 Routing Power Cables

Continuous metal conduit should be used for all power cables to reduce radiated electromagnetic interference (EMI). The conduit must be securely connected to the drive enclosure and the motor case for proper grounding. Consult local electrical code for proper grounding methods.

Route power cables through the supplied openings in the bottom of the enclosure. Use appropriate conduit or strain relief devices. Conduit hubs should be IMC or rigid steel conduit and should be UL listed. Conduit hub locations are shown in **Figure 6**.

**Important Note:** Remove all metal shavings after cutting new openings.

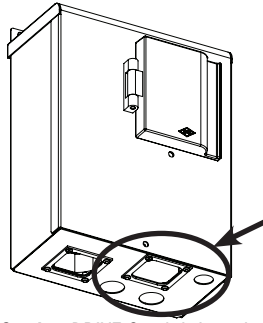

Figure 6 – AutoDRIVE Conduit Locations

### 3.9 Control Wiring

**! WARNING!** When the drive is turned OFF using a control switch connected to the AUX terminals, dangerous voltage may still be present on the input lines and elsewhere inside the enclosure.

The output of the drive can be controlled with a switch connected between the AUX1 and COM terminals and/or the AUX2 and COM terminals. The drive can also be controlled with a 4-20 mA transducer. Based on how the drive is configured, there may be delays in starting and stopping in order to prevent short cycling. Refer to pages 12-15 for more information on how to configure the VFD for each of these control options.

Figure 7 shows control terminal locations.

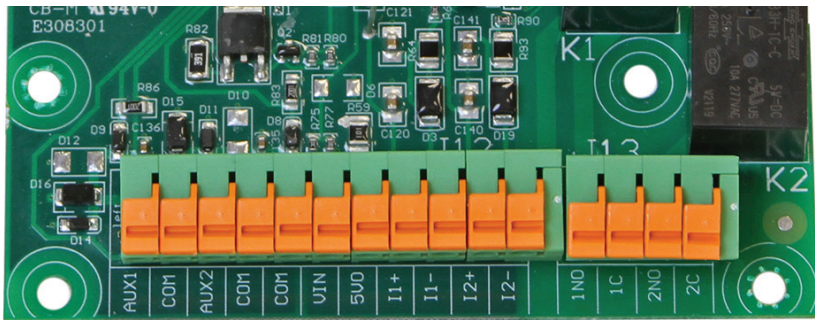

Figure 7 – Control Terminal Locations

**Table 6** – Describes the control wiring terminals.

See connection diagrams in **Figure 8**, pg. 13, **Figure 9**, pg. 14 and **Figure 10** pg. 15.

**Table 6 – Control Terminal Ratings and Descriptions**

| Terminal | Description           | Rating   | Comments  |
|----------|-----------------------|--|---|
| 1N0      | Normally Open Relay 1 | 0-30 VDC or 120 VAC, 10 A  | Normally open relay controlled by the conditions set in parameter Program Relay 1. See <b>Table 14</b> , pg. 29.  |
| 1C       | Common 1              |  | Common terminal for 1N0. <b>CAUTION!</b> Do not use as common for other terminals.  |
| 2N0      | Normally Open Relay 2 |  | Normally open relay controlled by the conditions set in parameter Program Relay 2. See <b>Table 14</b> , pg. 29.  |
| 2C       | Common 2              |  | Common terminal for 2N0. <b>CAUTION!</b> Do not use as common for other terminals.  |
| AUX1     | Auxiliary Input 1     | Dry contact type Pullup Voltage < 5 volts, galvanically isolated | Digital input. Commonly used for RUN/STOP command. Controlled by parameters AUX1 SELECT and AUX2 SELECT.  |
| AUX2     | Auxiliary Input 2     |  |   |
| COM      | Common                |  |   |
| 5V0      | 0-5 VDC Output        | 0-5 VDC  | 5 VDC supply to provide power to a potentiometer. Refer to <b>Table 14</b> , pg. 29 for details. See <b>Figure 10</b> for connection diagram.   |
| VIN      | 0-5 VDC Input         |  | Analog input for motor speed control. Speed is relative to scale of signal from 0 Hz to Max Frequency, set in Adjustable Parameter menu (default 60 Hz). Connect the wiper terminal of a potentiometer to this terminal as shown in <b>Figure 10</b> , pg. 15,. |
| COM      | Common                |  | Common for 0-5 VDC.   |
| I 1+     | 4-20 mA positive      | 4-20 mA  | Analog transducer connection for analog constant pressure or proportional motor speed control from a current source. Refer to <b>Table 14</b> , pg. 29 for details. See <b>Figure 9</b> , pg. 14, for a connection diagram.                                     |
| I 1-     | 4-20 mA negative      |  |   |
| I 2+     | 4-20 mA positive      |  |   |
| I 2-     | 4-20 mA negative      |  |   |

**⚠ CAUTION!** Electrostatic discharge (ESD) can damage electronic components. Discharge ESD prior to touching the board or to making connections. To discharge ESD, touch your hand to unpainted metal on the enclosure.

## Digital Pressure Switch

Follow these steps to connect a digital pressure switch:

1. Using the keypad, set the value of parameter **SYSTEM CONFIG** to 1. Refer to **Table 14**, pg. 29, *Interface Parameters*, or **Section 6.5**, pg. 38, *System Configuration*, for details.
2. Connect either wire of digital pressure switch to AUX1
3. Connect second wire of digital pressure switch to COM

The following steps detail connecting an overpressure switch (not provided by A.Y. McDonald).

4. Connect one wire of overpressure switch to AUX2
5. Connect second wire of overpressure switch to COM



**CAUTION!** By default, **AUX1** is programmed such that **OPEN=STOP, CLOSED=RUN** and **AUX2** is programmed such that **OPEN=RUN, CLOSED=STOP**. When **SYSTEM CONFIG = 2** (Analog CP), **AUX1** and **AUX2** are programmed such that **OPEN=RUN, CLOSED=STOP**. See parameters **AUX1 SELECT** and **AUX2 SELECT** to change this setting.

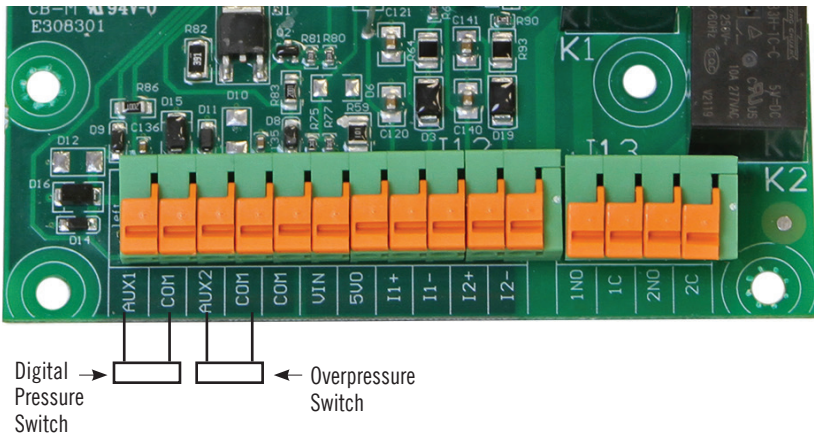

**Figure 8** – Connection Diagram for Digital Pressure Switch. Digital pressure switch connected to AUX1 and COM, overpressure switch connected to AUX2 and COM.

See **Section 7.2** pg. 41 for information on changing the pressure set point of the digital pressure switch.

## 4-20 mA Analog Transducer

Follow these steps to connect a 4-20 mA transducer:

1. Using the keypad, set the value of parameter **SYSTEM CONFIG** to 2 **Table 14**, pg. 29-30. See **Section 6.5**, pg. 38 *System Configuration*, and **Section 7**, pg. 39 *Constant Pressure Systems*, for more information.
2. Connect the positive lead (red) of the transducer to terminal I\_1+.
3. Connect the negative lead (black) of the transducer to terminal I\_1-.

**! CAUTION:** If the I+ and I- sensor cable is short circuited or if the sensor fails, the drive will stop and indicate a fault, **SENSOR CONNECTION FAIL**. Disconnect input power to the drive and fix the short circuit or replace the sensor.

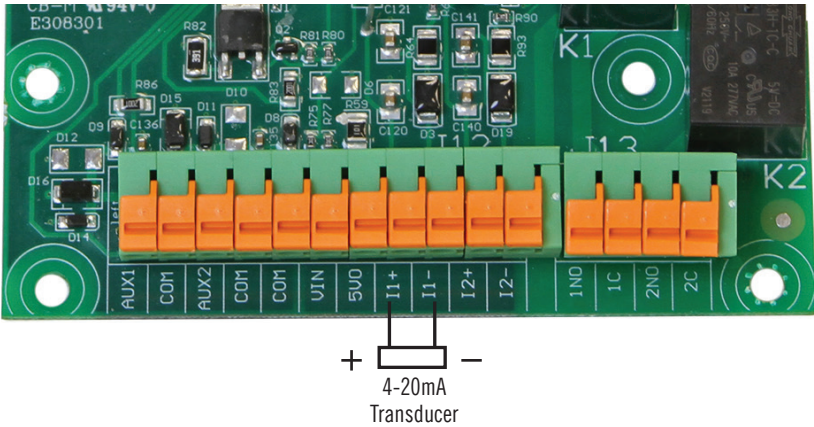

**Figure 9** – Connection Diagram for 4-20 mA Analog Transducer

**💡 Control Tip:** Turbulence near pressure switch or transducer can result in poor pressure control. For best results, pressure switches and transducers should be placed at least 6 inches away from pressure tanks, check valves, and pipe elbows.

## 0-5 VDC Potentiometer

Follow these steps to connect a 0-5 VDC potentiometer:

1. Using the keypad, set the value of parameter **SYSTEM CONFIG** to 3. Refer to **Table 14**, pg. 29-30, *Interface Parameters*, or **Section 6.5**, pg. 38, *System Configuration*, for details.
2. Connect the negative lead of the potentiometer to control terminal **COM**
3. Connect the wiper terminal of the potentiometer to the **V IN** terminal
4. Connect the positive lead of the potentiometer to the 5 VO terminal.

**! CAUTION:** By default, **AUX1** is programmed such that **OPEN=STOP, CLOSED=RUN** and **AUX2** is programmed such that **OPEN=RUN, CLOSED=STOP**. When **SYSTEM CONFIG = 2** (Analog CP), **AUX1** and **AUX2** are programmed such that **OPEN=RUN, CLOSED=STOP**. See parameters **AUX1 SELECT** and **AUX2 SELECT** to change this setting.

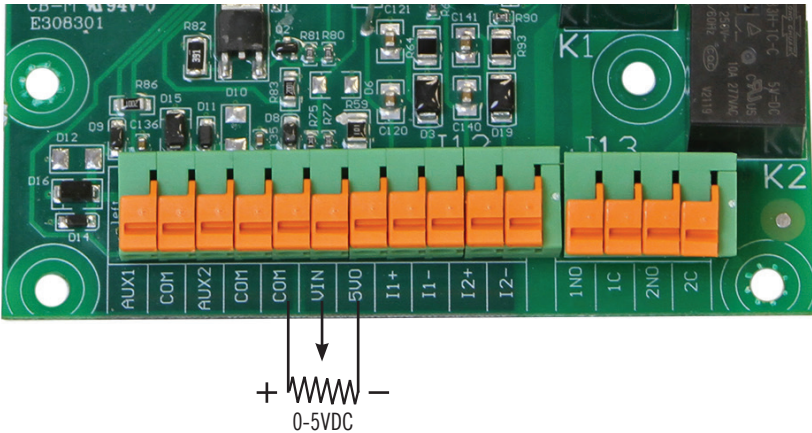

Figure 10 – Connection Diagram for 0-5 VDC Potentiometer

## 4 Using the Keypad and Display

AutoDRIVE VFDs are capable of many advanced, easy-to-use features that allow the user to protect the motor load from damage, monitor load conditions, log motor run time, troubleshoot the system, and more. The keypad is easy to use and understand, with 32-character text messages and an intuitive interface specifically tailored for pumping applications.

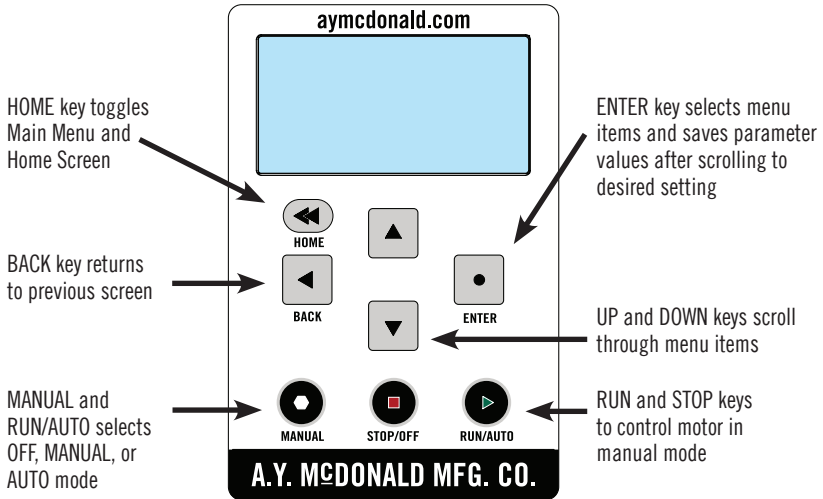

Figure 11 – Graphic Display and Keypad

### 4.1 Display Modes

After two minutes of keypad inactivity, the display will revert to the default display mode. Information on the display will vary based on the operating mode of the drive. When operating in AUTO mode with the factory default System Configuration 0, the display will indicate output amps (A), output frequency (Hz) and the status of the AUX1 and AUX2 inputs.

### 4.2 Password Protecting the Keypad

The keypad can be set up with a password to prevent unauthorized changes in adjustable parameters. The parameter **Password Setup** (Table 14, pg. 29-30) is used to protect the keypad. When this parameter has a value of zero the keypad is not protected. To password protect the keypad, enter a password consisting of a 4 digit number 0-9 and/or A-F letter as the parameter value. Contact customer service at 800-292-2737 if you lose or forget the password.



### 4.3 Keypad Display Messages

AutoDRIVE VFDs have several operating modes: AUTO, MANUAL, and OFF. The factory default operating mode is OFF. Operating Modes are detailed in **Table 7**.

**Table 7 – Operating Modes**

| Mode   | Description  |
|--------|--|
| Auto   | <p>With the AutoDRIVE set to AUTO mode and using a digital pressure switch, the motor load will automatically run if <b>AUX1</b> remote switch is closed and <b>AUX2</b> remote switch is open. Open <b>AUX1</b> or close <b>AUX2</b> to stop the motor or push STOP/OFF key.</p> <p>With the AutoDRIVE set to AUTO mode and using an analog pressure transducer, the motor load will automatically run if the system pressure is less than the setpoint and both <b>AUX1</b> and <b>AUX2</b> remote switches are open. Close <b>AUX1</b> or <b>AUX2</b> to stop the motor or push STOP/OFF key.</p> <p>The parameter, <b>ENABLE RESTARTS</b>, must be set to <b>YES</b> to allow automatic re-starts. See <b>Table 13</b>, pg. 28, <i>Auto-Restart Parameters</i> for details.</p> <p><b>! CAUTION:</b> By default, <b>AUX1</b> is programmed such that <b>OPEN=STOP, CLOSED=RUN</b> and <b>AUX2</b> is programmed such that <b>OPEN=RUN, CLOSED=STOP</b>. When <b>SYSTEM CONFIG = 2</b> (Analog CP), <b>AUX1</b> and <b>AUX2</b> are programmed such that <b>OPEN=RUN, CLOSED=STOP</b>. See parameters <b>AUX1 SELECT</b> and <b>AUX2 SELECT</b> to change this setting.</p> |
| MANUAL | <p>Activate MANUAL mode by pushing the <b>Manual</b> key until <b>Manual</b> appears on top left of the display. In Manual mode the motor load is controlled by using the <b>RUN</b> and <b>STOP</b> keys, which will override the <b>AUX1</b> and <b>AUX2</b> remote switches.</p> <p>Manual control of the drive through the keypad can be disabled through the parameter <b>Disable Manual Mode</b>. See <b>Table 14</b>, pg 29 <i>Interface Parameters</i>, for details.</p> <p><b>! CAUTION:</b> Operating the system in <b>MANUAL</b> mode on the keypad overrides signals from the pressures switches. Operating the system in this mode may lead to dangerous pressures in closed plumbing systems.</p> <p><b>! CAUTION:</b> If the 4-20 mA or 0-5 VDC control terminals are short circuited, power will be lost to the keypad. If the drive is in <b>MANUAL</b> mode, the drive will not respond to a <b>STOP</b> command on the keypad. Disconnect input power to the drive to stop the motor and then fix the short circuit.</p>  |
| OFF    | <p>The factory default operating mode is OFF. The adjustable parameter, <b>Enable Restarts</b>, must be set to “yes” to allow automatic re-starts. To exit <b>AUTO</b> mode, press the <b>STOP/OFF</b> key until <b>OFF</b> appears on top left of the display. If the motor is running, it will stop. To restart the motor, revert to either <b>AUTO</b> mode or <b>MANUAL</b> mode. Certain faults can also be cleared by pressing the up and down arrow keys at the same time and holding for one second.</p>   |

### 4.4 Keypad Main Menu Items

The HOME key toggles between the Home screen (operating status screen) and the Main Menu items. Use the UP and DOWN arrows to scroll through the Main Menu items. Press ENTER to view or edit a Main Menu item.

**Figure 12**, pg. 18 contains a brief description of Main Menu items, followed by in-depth instructions on the use and function of each Main Menu item.

Press HOME, then use UP and DOWN arrow keys to scroll through Main Menu items

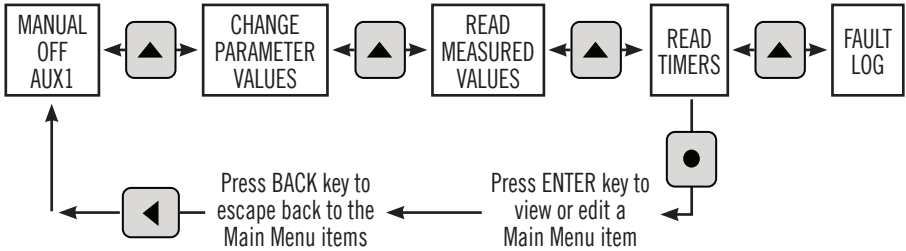

**Figure 12** – Navigating Main Menu Items

**Table 8** – Main Menu Items

| Display Message         | Description  |
|-------------------------|--|
| CHANGE PARAMETER VALUES | Allows the user to set values for functions such as motor overload settings, dry well condition, time to restart after a fault, etc.   |
| CLEAR MEMORY            | This function clears the Fault Log and Timers. All fault counters in the Fault Log will be reset to zero. If any number of automatic restarts have been allowed through parameters in the Auto Restart Parameters (Table 13, pg. 28), the counter on these faults will be set to zero. |
| FAULT LOG               | A re-settable fault log that records the number of times a particular fault has occurred. The number of faults counted in this log can be cleared through the CLEAR MEMORY menu.   |
| READ TIMERS             | Records motor run time and drive on time.  |
| READ MEASURED VALUES    | Displays measured values such as output current, input voltage, frequency, etc.  |

## 4.5 Change Parameter Values

The Main Menu item, **CHANGE PARAMETER VALUES**, leads to several sub-menus that contain adjustable operating parameters. These parameters provide basic functions such as motor overload protection and advanced features that allow you to customize operation of the drive to fit your application.

The following **Section 5**, pg. 23, *Adjustable Parameters*, contains a complete list of the parameters along with a description of their function and instructions on setting them.

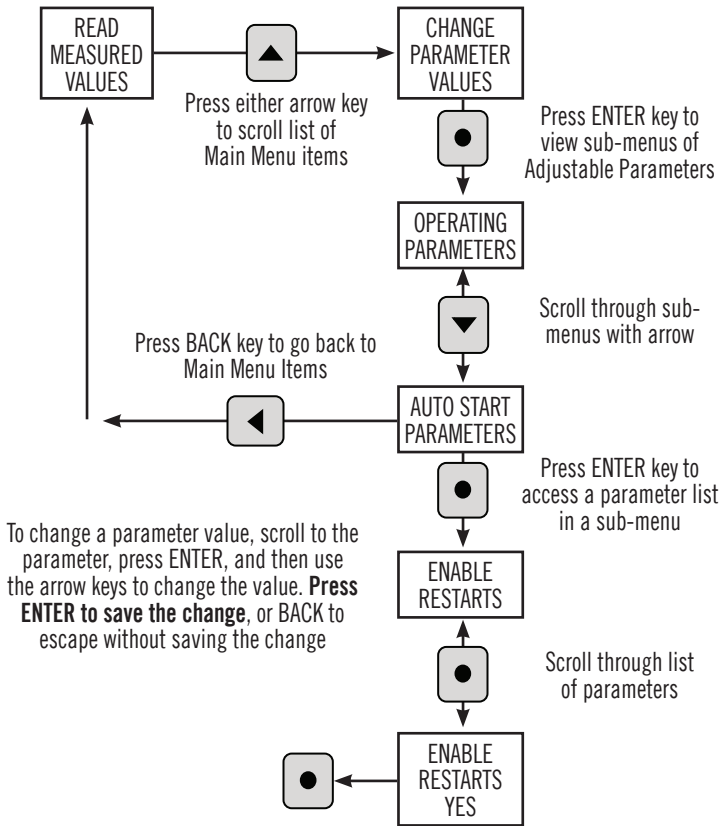

Figure 13 – Change Parameter values

## 4.6 Read Measured Values

The display can provide a variety of measured values related to the performance of the drive and its load, such as amps, voltages and frequency. To read measured values:

1. Press the HOME key to access Main Menu items, and then scroll with arrow keys until **READ MEASURED VALUES** appears on the display.
2. Press ENTER to access this menu item.
3. Use the up and down arrow keys to scroll through the various values that you wish to read.



### Programming Tip

Press the HOME key at any time to return Home screen (operating status screen).

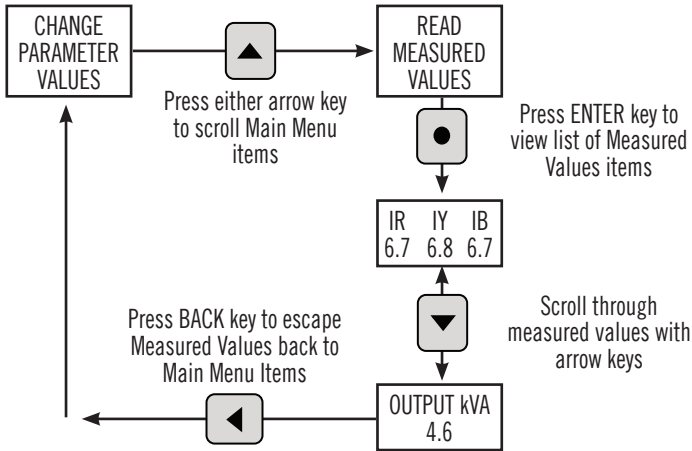

**Figure 14 – Read Measured Values**

**Table 9 – Measured Values**

| Display Message         | Description of Measured Value  |
|-------------------------|--|
| IR IY IB                | Output currents measured in Amps   |
| OUTPUT kVA              | Output measured in kVA   |
| BUS CAP VOLTAGE         | Voltage of the DC bus  |
| INPUT VOLTAGE           | Input voltage AC   |
| AUX1 AUX2               | ON/OFF status of the remote switch circuits AUX1 and AUX2  |
| FREQUENCY               | Output frequency in Hz   |
| MODEL NUMBER            | Displays the AutoDRIVE product model number  |
| V 5VDC IN               | Displays the 0-5 VDC analog control voltage between Control Terminals for 0-5VDC input.            |
| 4-20mA INPUT, I_1 & I_2 | Displays 4-20 mA analog control currents on I_1 & I_2 Control Terminals for analog current inputs. |
| IGBT CASE TEMP          | IGBT case temperature.   |

## 4.7 Read Timers

The timer function records the motor run time in hours, and the time the drive has been energized. There are two timers for each function, one which can be reset, and one permanent. To view and reset the timers:

1. Press the MENU key to scroll through menu items until **READ TIMERS** appears on the display.
2. Press ENTER to enter this menu item.
3. Use the up and down arrows to scroll through the clock functions.
4. To reset the clock timers, navigate to the Main Menu item, **CLEAR MEMORY**, press ENTER, and then use arrow keys to select **RESET TIMERS**. Press ENTER to reset the timers.

Table 10 – Timers

| Timer           | Description   |
|-----------------|---|
| ALL MOTOR HOURS | Logs total motor run time. Not resettable.              |
| ALL DRIVE HOURS | Logs total time the drive is energized. Not resettable. |



### Programming Tip

To reset the timers, navigate to the Main Menu item, **CLEAR MEMORY**, use arrow keys to select **RESET TIMERS**, and then press ENTER.

## 4.8 Clear Memory

The **CLEAR MEMORY** function in the Main Menu resets the motor run timer, drive on time (powered up) timer and the Restart Log which counts faults by type.

1. Press the MENU key then use the ARROW keys to scroll through menu items to **CLEAR MEMORY**.
2. Press ENTER to select **CLEAR MEMORY**.
3. Use the up and down arrows to find either **RESET TIMERS** or **CLEAR RESTART LOG**.
4. Press ENTER to reset the selected function.

## 4.9 Restart Log

The Restart Log counts the times each fault type has occurred. The fault counters are resettable and are tied to automatic restart fault types. Automatic restarts are programmed through the AUTO RESTART PARAMETERS, a sub-menu of CHANGE PARAMETER VALUES.

To view the FAULT LOG:

1. Scroll through menu items until **FAULT LOG** appears on the display.
2. Press ENTER to access this menu item.
3. Use the up and down arrows to scroll through the faults.
4. The fault will appear on the first row of the display, followed by the number of times that fault has occurred.

To clear the **FAULT LOG** and reset all Auto-Restart fault counters:

1. Scroll through menu items until **CLEAR MEMORY** appears on the display.
2. Press ENTER.
3. Use the up and down arrows to find **CLEAR RESTART LOG**.
4. Press ENTER to clear the Restart Log and reset all Auto Restart fault counters.



**CAUTION:** Clearing faults through the **CLEAR MEMORY** menu will clear ALL faults in the Restart Log and all fault counters will be reset to zero. If any number of automatic restarts have been allowed through parameters in the Auto Restart Parameters (**Table 13**, pg. 28), the counter on these faults will be set to zero.



### Programming Tip

When the drive has faulted and is programmed to automatically restart after a time delay, the display will count down the remaining time to start. Press both up arrow and down arrow for one second to interrupt the countdown and start the motor.

If the drive has faulted and no auto restart is allowed, the display will indicate the type of fault that has occurred on the top line and the second line will read **RESTART? ENTER**. Press ENTER to clear the fault and restart the load.

The number and type of faults are also recorded in the Fault Log. In this Log each fault is recorded with a time and date stamp (up to the most recent 20 faults). The Fault Log is permanent and cannot be cleared. See **Section 8.1**, pg. 49, for more information on the Fault Log.

## 5 ADJUSTABLE PARAMETERS

### 5.1 Changing Parameter Values



**WARNING:** When the drive is set to automatically restart after a fault, the output terminals can energize and the load can start without warning, exposing the user to risk of serious injury. Make certain the input is de-energized before approaching the equipment. The default setting **ENABLE RESTARTS** allows the unit to automatically restart after certain faults. To disable this parameter, see **Table 13**, pg. 28.

The Change Parameter Values function allows the user to set values for a variety of functions including motor overload settings, number of restarts after a fault, ramp time, maximum frequency, and more. To change parameter values:

1. Use the keypad to navigate to **CHANGE PARAMETER VALUES** in the menu.
2. Press ENTER to access this menu item.
3. There are multiple sub-menu items under **CHANGE PARAMETER VALUES**. Use the up and down arrows to scroll through the sub-menu to find the item desired, and then press ENTER. See **Table 12**, pg. 26 through **Table 15**, pg. 31-32, for a list of parameters with a description.
4. Use the up and down arrow keys to scroll to the parameter you want to set, press ENTER, then use the up and down arrows to select a new value for that parameter.
5. When the value you want appears on the display, press ENTER to select that value.
6. To escape the parameter without selecting or resetting the value, press the BACK key, which will return you to the list of parameters.



#### Programming Tip

Press the ENTER key to move to lower levels of the menu outline or to save a new parameter value. Press the BACK key to move to higher levels in the menu outline or to escape a parameter setting without changing the value.

### 5.2 Restore Default Parameter Settings

To restore **ALL\*** adjustable parameters to their default value, press and hold the **BACK** and **ENTER** keys at once and hold for three seconds. The display will prompt if you would like to reset the drive. If you select yes, the display will read **"RESETTING PLEASE WAIT"**. If a User Password is configured, you will first be prompted to enter the Password. You will then be prompted to press **ENTER** for "yes" or **BACK** for "no."

#### \*Important Note:

The restore function will not affect **USER PASSWORD**, **SWITCHING FREQUENCY** and **REVERSE ROTATION**. (3 phase motors only)



#### Programming Tip

The reset function is disabled while the motor is running. Make certain the motor is stopped before resetting. Make sure to press both keys at once and hold 3 seconds to reset.

To reset an individual parameter to its default value, you must refer to the appropriate table of Adjustable Parameters, find the default value, re-enter the default value, and save it. See **Table 12 - Table 15**, pg. 26-32 for a complete list of Adjustable Parameters, their

## 5.3 Auto Restarts

The drive can be programmed to automatically restart after certain faults. Using the Auto Restart Parameters (see **Table 13**, pg. 28), you can set a time delay before the drive starts after a fault and select the number of automatic restarts allowed before the unit will remain OFF after a fault.

For example, you may wish to allow 10 automatic restarts after a fault for **Dry Well** but require the drive to remain off for one hour to allow the well to recover before restarting. When the drive is counting down the time to restart after a fault, the display will indicate the time until restart (in seconds).



### Programming Tip

To interrupt the countdown and allow a restart, push and hold both the **UP** arrow and **DOWN** arrow for one second. The load will start immediately.

When the drive reaches the limit of faults set by the adjustable parameter, it will remain OFF and the display will indicate the type of fault on the top line. The second line will read **RESTART? ENTER**. Press **ENTER** to clear the fault and restart the load. The fault counters in the Restart Log will all be reset to zero. See **Section 4.9**, pg. 22, *Restart Log*, for more information.

Some faults do not allow auto restart. The display will read **NO AUTO RESTART**.



## 5.4 Menu Structure Overview

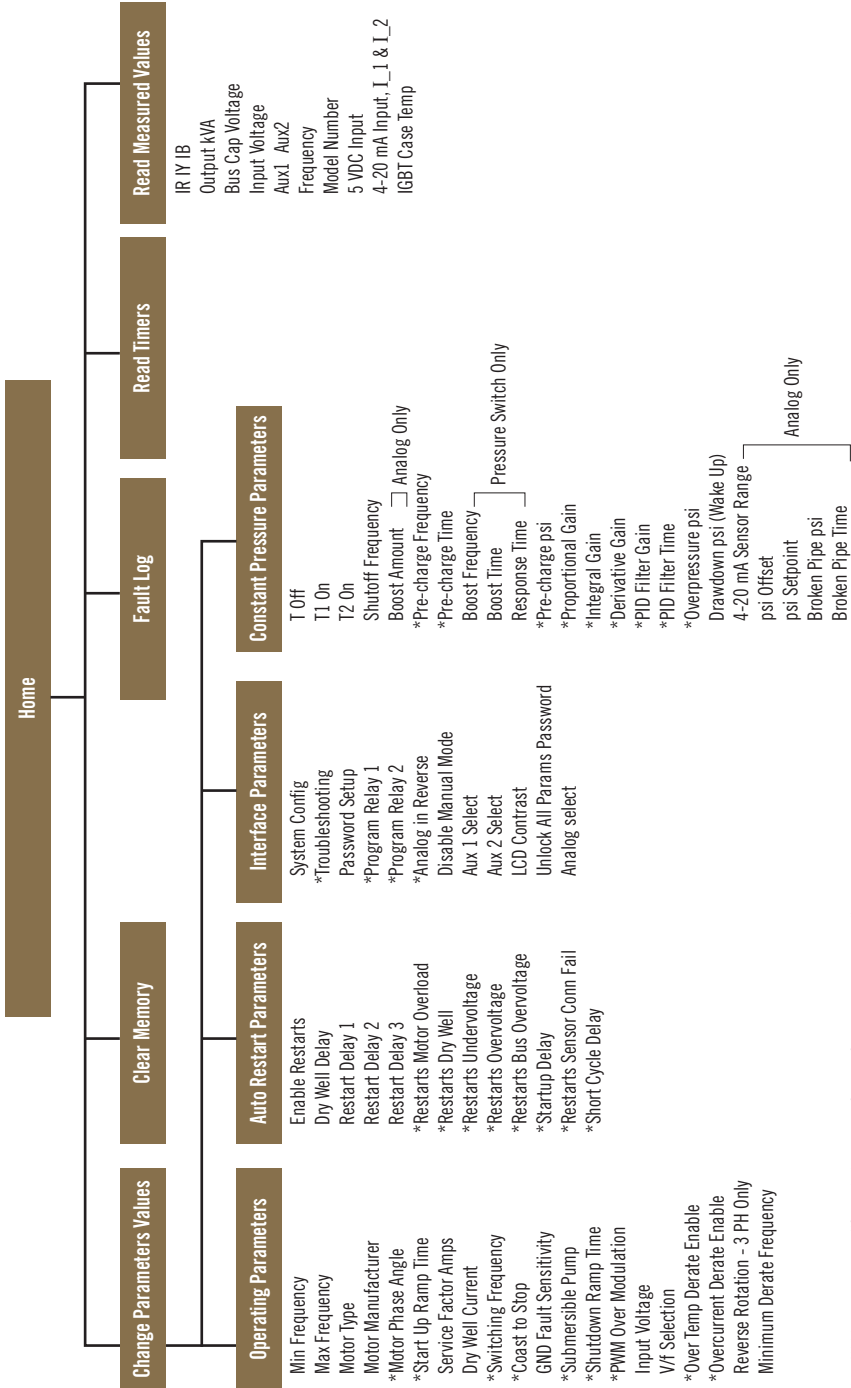

\* = Hidden parameter (if needed, contact factory for access password)

**Table 12 – Operating Parameters**

| Display Message                          | Description   | Default / Min / Max Value                   |
|--|---|---|
| MIN FREQUENCY                            | Minimum output frequency allowed except during startup ramp.  | 35/5/120                                    |
| MAX FREQUENCY                            | Maximum frequency allowed, or target frequency at start-up ramp. This parameter value cannot be set lower than <b>MINIMUM FREQ.</b>   | 60/5/300                                    |
| MOTOR TYPE                               | Used to select two-wire or three-wire motor.  | two-wire/two-wire/three-wire                |
| MOTOR MANUFACTURER                       | Select the motor manufacturer to optimize performance. When “Franklin” is chosen, the drive will be compatible with motors containing BIAC switches. Options include: A.Y. McDonald, Franklin, Pentek, Grundfoss, and Other (if “Other” is selected, you will be prompted to select <b>Motor Phase Angle.</b> )                                   | Default: A.Y. McDonald                      |
| *MOTOR PHASE ANGLE                       | For 3-wire drives only when “Other” is selected for <b>Motor Manufacturer</b> . Use this to select <b>Phase Angle</b> based on motor specs. Adjust <b>Phase Angle</b> to reach desired torque.  | Based on <b>MOTOR MANUFACTURER</b> /100/180 |
| *START UP RAMP TIME                      | Time in seconds from <b>Min Frequency</b> to <b>Max Frequency</b> . Ramp speed is linear.<br><br>In constant pressure, <b>Integral Gain</b> will override this value. Increasing <b>Integral Gain</b> will reduce error constant so ramp time is closer to <b>Startup Ramp Time</b> value. Decreasing <b>Integral Gain</b> will extend ramp time. | 3/1/120                                     |
| SERVICE FACTOR AMPS                      | Setting for motor overload protection, Trip Class 10 curve.   | 12/3/16                                     |
| Dry Well Current (Undercurrent Setpoint) | Drive faults when output current goes below the set value (dry well protection).  | 0/0/12                                      |
| *Switching Frequency                     | Switching frequency of the IGBT inverter module.  | 3k/2k/8k                                    |
| *Coast To Stop                           | Selects between coast to stop or ramp to stop. Ramp profile is controlled by parameter <b>Shutdown Ramp</b> .<br>NO = ramp to stop, YES = coast to stop   | Default: YES                                |

\* = Hidden parameter (if needed, contact factor for access password)

| Display Message                       | Description   | Default / Min / Max Value     |
|---------------------------------------|---|-------------------------------|
| GND Fault Detect<br>Fault Sensitivity | Detects a fault between any output line and earth. Sensitivity to fault detection is adjustable to avoid nuisance trips. Parameter is disabled by default. Lower value equals lower sensitivity to fault detection.   | Disabled/1/9                  |
| *SUBMERSIBLE<br>PUMP                  | <p>If enabled, frequency will ramp from stop to the value set by parameter <b>Minimum Frequency</b> in one second. Submersible pumps suffer damage to the thrust bearing if operated below 30 Hz for more than 1 second.</p> <p>YES = one second ramp time from stop to <b>Minimum Frequency</b>, then will follow <b>Start Up Ramp Time</b> to <b>Maximum Frequency</b>.</p> <p>NO = linear ramp time from stop to <b>Maximum Frequency</b>. Minimum frequency is still observed while the motor is running.</p> | Default: Yes                  |
| *SHUTDOWN RAMP<br>TIME                | Time in seconds from <b>Max Frequency</b> to <b>Min Frequency</b> . Ramp time is linear. Factory default setting enables the <b>Coast to Stop</b> parameter which disables the <b>Shutdown Ramp</b> parameter.  | 3/1/120                       |
| *PWM Over<br>Modulation               | Increases the output voltage.<br><br>If input voltage is below nominal voltage, output voltage could be low. Monitor output voltage and use this parameter to boost output voltage if necessary.  | 0/0/25%                       |
| Input Voltage                         | Used to select nominal incoming voltage to the system.  | 240/120/240                   |
| V/f Selection                         | Controls the relationship between voltage and frequency when starting a motor for different applications.<br><b>Standard:</b> Voltage and frequency are proportional. Torque is constant.<br><b>Soft Start:</b> Limits voltage during initial ramp to reduce inrush current. Torque is reduced.   | Default: Soft Start           |
| Over Temp Derate<br>Enable            | Frequency will slow down to avoid drive over temperature fault but will not go below <b>Minimum Derate Frequency</b> . Screen will indicate <b>Over Temp Derate</b> when conditions apply.  | Default: Yes                  |
| Overcurrent<br>Derate Enable          | Frequency will slow down to avoid motor overcurrent fault but will not go below <b>Minimum Derate Frequency</b> . Screen will indicate <b>Overcurrent Derate</b> when conditions apply.   | Default: Yes                  |
| Reverse Rotation -<br>3 PH Only       | Reverses motor direction by changing sequence of output phase rotation. (3 phase only)  | Standard ABC /<br>Reverse ACB |
| Minimum Derate<br>Frequency           | In Hz. This is the minimum frequency the drive will derate to due to OVER TEMP DERATE or OVERCURRENT DERATE.  | 45/0/120                      |

\* = Hidden parameter (if needed, contact factor for access password)

**Table 13 – Auto-Restart Parameters**

| Display Message               | Description  | Default / Min / Max Value |
|-------------------------------|--|---------------------------|
| Enable Restarts               | Controls the ability of the drive to automatically restart after a fault and to initialize in AUTO mode.<br>NO = no auto restarts and unit will initialize in OFF mode<br>YES = Auto mode on initialization and auto restarts allowed  | Default: YES              |
| Dry Well Delay                | Time in seconds dry well is allowed before unit trips  | 4/0/9999                  |
| Restart Delay 1               | Delay in seconds before unit restarts after a trip due to: <ul style="list-style-type: none"> <li>Motor Overload</li> </ul>  | 60/0/9999                 |
| Restart Delay 2               | Delay in seconds before unit restarts after a trip due to: <ul style="list-style-type: none"> <li>Bus Overvoltage</li> <li>Dry Well Current</li> <li>Current Unbalance</li> <li>4-20 mA Sensor signal</li> </ul>   | 15/0/9999                 |
| Restart Delay 3               | Delay in seconds before unit restarts after a trip due to: <ul style="list-style-type: none"> <li>Hall Sense High</li> <li>Low Input Voltage</li> <li>High Input Voltage</li> </ul>  | 15/0/9999                 |
| *Restarts Motor Overload      | Number of automatic restarts allowed due to motor overload current set by parameter <b>Overcurrent Limit</b> (see Note 1, pg. 33)  | 4/0/9999                  |
| *Restarts Dry Well            | Number of automatic restarts allowed due to under current and minimum power trip (see Note 1, pg. 33)  | 10/0/9999                 |
| *Restarts Undervoltage        | Number of automatic restarts allowed due to low input voltage trip (see Note 1, pg. 33)  | 10/0/9999                 |
| *Restarts Overvoltage         | Number of automatic restarts allowed due to high input voltage trip (see Note 1, pg. 33)   | 10/0/9999                 |
| *Restarts Bus<br>*Overvoltage | Number of automatic restarts allowed due to DC bus overvoltage (see Note 1, pg. 33)  | 10/0/9999                 |
| *Start Up Delay               | Delay in seconds before unit restarts after an input power OFF/ON cycle. (See Note 2, pg. 33)  | 0/0/9999                  |
| *Restarts Sensor Conn Fail    | Number of automatic restarts allowed due to loss of 4-20mA analog input signal (see Note 1, pg. 33)  | 10/0/9999                 |
| *Short Cycle Delay            | Delay in seconds before motor starts after a RUN command. Prevents the drive from engaging the motor when it is spooling down during coast-to-stop operation. Delay affects both manual RUN command from the keypad and RUN command from external signals in auto mode. Display will count down seconds until RUN during delay. (See Note 2, pg. 33) | 3/0/300                   |

\* = Hidden parameter (if needed, contact factor for access password)

**Table 14 – Interface Parameters**

| Display Message   | Description   | Default / Min / Max Value |
|---|---|---------------------------|
| System Config<br>(see Section 6.5 for detailed information) | <p>Sets the system configuration = 0, 1, 2, 3<br/> <b>WHEN <i>SYSTEM CONFIG</i> = 0 (ON/OFF) RUN/STOP CONTROL USING AUX1 AND AUX2. WHEN <i>SYSTEM CONFIG</i> = 1 (DIGITAL CP). BOTH AUX1 AND AUX2 MUST HAVE A CONTACT CLOSURE TO RUN. BY DEFAULT, <i>AUX1</i> is programmed such that <b>OPEN=STOP, CLOSED=RUN</b> and <i>AUX2</i> is programmed such that <b>OPEN=RUN, CLOSED=STOP.</b></b></p> <p>When <i>System Config</i> = 2 (Analog CP) or 3 (Speed Control), <i>AUX1</i> and <i>AUX2</i> are programmed such that <b>OPEN=RUN, CLOSED=STOP.</b> See parameters <i>AUX1 Select</i> and <i>AUX2 Select</i> to change this setting.<br/>                     1 = Digital constant pressure control<br/>                     2 = Analog constant pressure control<br/>                     3 = 0-5 VDC speed control (potentiometer)</p> | 0/0/3                     |
| *Troubleshooting  | Factory assisted use only. Contact manufacturer.  | 0/0/5                     |
| Password Setup  | Allows keypad to be password protected. When keypad is locked, parameters and values can be viewed but not changed. Parameter value of zero disables password protection. Use arrows to scroll to a value that will become the password.  | 0000/<br>0000/<br>9999    |
| *Program Relay 1  | <p>Programmable normally open relay. Control terminals COM, 1NO. The relay can be programmed to change state for the following conditions:<br/>                     0 = System Fault<br/>                     Closed = normal, Open = fault<br/>                     1 = Reserved<br/>                     2 = Reserved<br/>                     3 = Reserved<br/>                     4 = Pump Fault e.g. motor overload, dry well, etc.<br/>                     Closed - normal operation, Open = fault<br/>                     5 = Minimum frequency. Relay changes state when motor frequency is greater than the value set by parameter <i>MIN FREQUENCY.</i> (see Note 2, next page)<br/>                     When lead/lag pump control has been selected, it will override programmable Relays 1, 2.</p>                          | 0/0/5                     |
| *Program Relay 2  | Programmable normally open relay. Control terminals 2NO, 2C. See Parameter <i>PROGRAM RELAY 1</i> above for description of values.  | 0/0/5                     |
| *Analog in Reverse  | Reverses the scale of the analog signal, both 0-5VDC and 4-20mA. For example, in normal 0-5VDC signal, 0V = low and 5V = high. In reverse, 5V = low and 0V = high.<br>No = Normal, Yes = Reverse (Pump Down)  | Default: No               |
| Disable Manual Mode   | Disables manual operation of the drive through the keypad. Operating states are limited to Auto and OFF.<br>YES = Manual mode disabled  | Default: Yes              |

\* = Hidden parameter (if needed, contact factor for access password)

**Table 14 – Interface Parameters**

| Display Message            | Description  | Default / Min / Max Value  |
|----------------------------|--|--|
| AUX1 Select                | <p>Programmable digital input. Generally used for motor Run/Stop control.</p> <p>0 = RUN/STOP (closed = RUN, open = STOP)</p> <p>1 = RUN/STOP (closed = STOP, open = RUN)</p> <p>2 = Always in RUN mode (no jumper or switch required)</p>   | <p>0/0/2</p> <p>If <b>System Config</b> =<br/>2 (Analog CP):<br/>1/0/2</p> |
| AUX2 Select                | <p>Programmable digital input. Generally used for motor Run/Stop control.</p> <p>0 = RUN/STOP (closed = RUN, open = STOP)</p> <p>1 = RUN/STOP (closed = STOP, open = RUN)</p> <p>2 = Always in RUN mode (no jumper or switch required)</p> <p>3 = Reverse Rotation</p> <p>Function of these inputs can change when certain System Configuration settings are chosen. See <b>Section 6.5</b>, pg. 38 for additional info.</p> | <p>1/0/2</p> <p>If <b>System Config</b> =<br/>2 (Analog CP):<br/>1/0/2</p> |
| LCD Contrast               | Used to adjust the contrast and readability of the graphic display.  | 40/30/63   |
| Unlock All Params Password | Contact factory for access.  |  |
| Analog Select              | <p>0 = I_1 ON</p> <p>1 = I_2 ON</p> <p>2 = I_1 ON, I_2 redundant</p> <p>3 = I_2 ON, I_1 redundant</p>  | 0/0/3  |

**Table 15 – Constant Pressure Parameters**

| Display Message       | Description  | Default / Min / Max Value |
|-----------------------|--|---------------------------|
| T Off                 | In seconds. Used to prevent short cycling in CP systems. If the motor was off during the last cycle for a period greater than <b>T Off</b> , the minimum on time of the motor is <b>T1 On</b> . If the motor was off for a period less than <b>T Off</b> , the minimum on time of the motor is <b>T2 On</b> . Default values give a minimum cycle time of about 1 minute.  | 30/0/1000                 |
| T1 On                 | In seconds. See <b>T Off</b> above. <b>T1 On</b> should be set to be less than <b>T2 On</b> .  | 15/0/1000                 |
| T2 On                 | In seconds. See <b>T Off</b> above. <b>T1 On</b> should be set to be less than <b>T2 On</b> .  | 30/0/1000                 |
| Shutoff Frequency     | In Hz. This parameter value is <b>added</b> to the frequency set by the parameter <b>Minimum Frequency</b> . The combined value is the frequency at which drive will enter sleep mode when pressure is controlled at the set point.  | 12/0/300                  |
| *Pre-charge Frequency | In Hz. Sets the maximum frequency applied to the motor during the pre-charge interval.   | 35/1/120                  |
| *Pre-charge Time      | In minutes. Sets the maximum time for pre-charge regardless of any sensor inputs. A setting of zero disables the pre-charge mode.  | 0/0/30000                 |
| *Pre-charge psi       | Used only for analog CP systems. Pre-charge will be terminated when pressure reaches this set point. Should be set less than <b>psi Setpoint</b> .   | 20/0/200                  |
| *Proportional Gain    | Multiplier for the analog error signal in an analog constant pressure system. When parameter is set to a value of zero the keypad displays <b>SIMPLE MODE</b> and the controller switches to an algorithm which does not require a gain setting. See <b>Section 7.9</b> , pg. 48 Troubleshooting Constant Pressure Systems, for details. When using PI control, best results will be obtained by starting with a value of 5 for <b>Proportional Gain</b> . | 5/simple mode/60          |
| *Integral Gain        | Multiplier for the integral term in PI control of analog constant pressure. Used to fine tune control of unstable systems. Parameter is disabled when <b>Proportional Gain</b> is set to <b>SIMPLE MODE</b> . See <b>Section 7.9</b> , pg. 48 for details.   | 30/0/1000                 |
| *Derivative Gain      | Used to reduce overshoot and oscillation. Should be used only when necessary because it tends to amplify noise in the transducer signal. It may cause the system to become unstable.   | 0/0/50                    |
| *PID Filter Gain      | Controls the rate of frequency increase in response to the error term.   | 0/0/100                   |
| *PID Filter Time      | Sample interval for the PID Filter Gain.   | 1/0/10                    |

\* = Hidden parameter (if needed, contact factor for access password)

| Display Message        | Description   | Default / Min / Max Value |
|------------------------|---|---------------------------|
| *Overpressure psi      | This value is added to the value set by parameter <i>psi Setpoint</i> . The combined value is the pressure at which drive will stop the motor load. Motor will restart when the pressure falls to the value set by parameter <i>Draw Down psi</i> . | 20/0/500                  |
| Drawdown psi (Wake Up) | In psi. Provides hysteresis during sleep mode. Parameter controls the pressure drop below <i>psi Setpoint</i> to start motor in sleep mode, e.g. if psi ON = 5 and motor turns off at 50 psi, motor will restart at 45 psi.                         | 5/0/50                    |

The following parameters are only accessible when using Digital Constant Pressure. See Section 7.3, on page 42, for additional information.

|                 |   |                      |
|-----------------|---|----------------------|
| Boost Frequency | Frequency (Hz) the system will change to when it is boosting pressure.  | 15/0/30              |
| Boost Time      | Time (seconds) the system will boost before shutting off.   | 6/0/120              |
| Response Time   | This determines how quickly the drive will respond to pressure fluctuations due to site-specific pipe and tank configurations. Select <b>QUICK</b> for large systems, <b>AVERAGE</b> for medium systems, and <b>SLOW</b> for small systems. | AVERAGE/ SLOW/ QUICK |

The following parameters are only accessible when using Analog Constant Pressure. See Section 7.3, on page 42, for additional information.

|                      |   |            |
|----------------------|---|------------|
| Boost Amount         | In psi. The parameter value specifies a pressure increase in psi before sleep mode. The value is added to <i>psi SETPOINT</i> .   | 0/0/100    |
| 4-20 mA Sensor Range | In psi. This value should be set to the maximum psi of the 4-20 mA transducer being used for constant pressure control i.e. if the transducer has a range of 0-150 psi the parameter should be set to 150. This parameter is critical for accurate pressure control.  | 150/50/500 |
| psi Offset           | This is used to calibrate the pressure that the VFD registers from pressure transducer if a manual pressure measurement is not equal to what VFD is reading. For instance, if VFD reads 40 psi, but manual measurement shows 50 psi, this setting should be set to +10.   | 0/-50/50   |
| psi Setpoint         | In psi. This sets the level at which the pressure will be controlled. Must be set as a psi value within in the range of the 4-20 mA transducer. Make sure the value of the parameter <i>4-20 mA psi Sensor Range</i> is set to the maximum psi value of the sensor being used. Make sure the proper <i>SYSTEM CONFIG</i> parameter is set to 2. See Section 6.5, pg. 38, System Configuration, for details. See Section 7, Constant Pressure Systems, for instructions on using advanced control options. | 50/0/200   |
| Broken Pipe psi      | psi at which unit will determine there is a broken pipe. Value of zero disables this feature.   | 0/0/150    |
| Broken Pipe Time     | In minutes. Time at which measured pressure is below <b>Broken Pipe psi</b> before unit faults.   | 0/0/9999   |

\* = Hidden parameter (if needed, contact factor for access password)



**Note 1:** The restart counter must be cleared to begin counting the number of restarts from zero. Main Menu item, Clear Memory, resets the fault counters. See **Section 4.4**, pg. 17, *Keypad Main Menu Items*, for more information.

**Note 2:** Push the up arrow key and down arrow key simultaneously to interrupt the countdown delay and allow an auto restart.

## 6 OPERATION

### 6.1 Commissioning the Unit

It is always advisable to check the condition of the drive and its load before starting regular operation.

#### Initial Operation

Verify the following:

1. The unit is securely attached to the proper mounting surface
2. The unit's input terminals are connected to an appropriate power source
3. An appropriately rated motor is connected to the output terminals
4. The motor is secured and properly mounted

## Constant Pressure Setup

Upon the first initialization of the unit (or after restoring factory defaults of all parameters using the two-button reset procedure, page 23) the drive will enter into the following set of questions in order to setup the constant pressure system.

### Single Phase

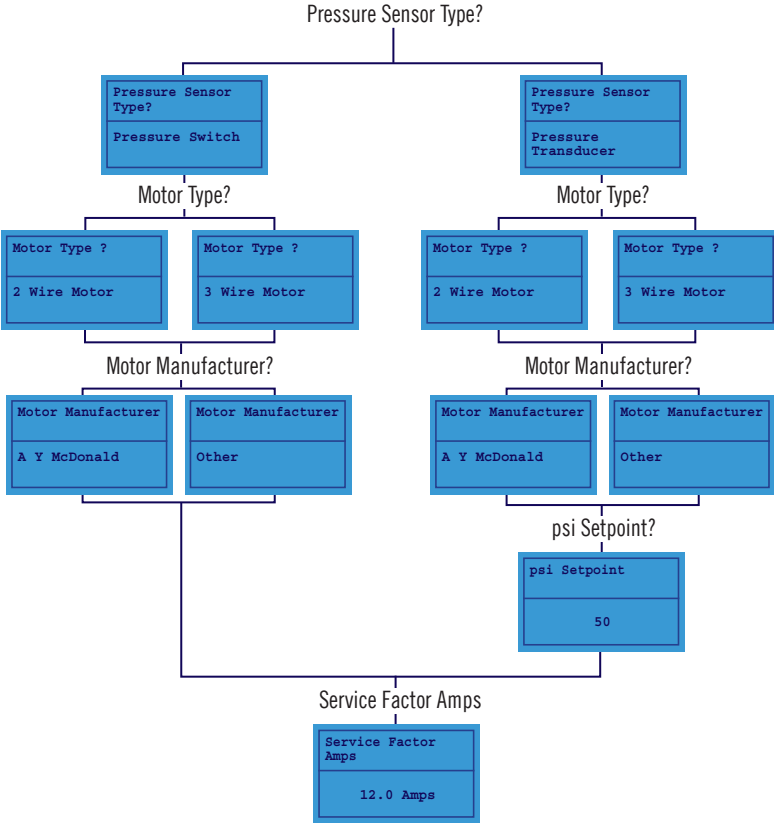

### Three Phase

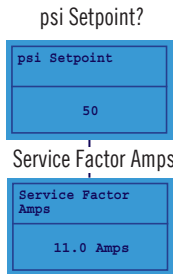

## 6.2 Ground Fault Detection

AutoDRIVE VFDs are equipped with a feature to detect a fault between any of the output lines and earth. See **Table 12**, pg 26, Operating Parameters, **GND FAULT DETECT**, for more information on using this parameter. If a ground fault is strong enough to trigger the parameter **GND FAULT DETECT**, the drive will not allow the IGBTs to switch. However, this does not protect the drive from damage in all situations. **If a ground fault occurs, immediately disconnect the input power!** Long motor leads and a dV/dT filter can cause nuisance indications of a ground fault. If a megger does not indicate a ground fault, the sensitivity of the ground fault detection may need to be reduced by reducing the value of parameter **GND FAULT DETECT**.

**!** **CAUTION:** Before the motor is connected to the output terminals, check all output lines for line-to-ground faults using a megger. There is a direct path through the drive circuitry for ground fault currents that can be triggered when power is applied to the input terminals, even though the output switches are not activated. These currents can cause serious damage to drive circuitry and are not covered under warranty.

**!** **WARNING!** If the parameter **ENABLE RESTARTS** has been set to allow restarts, the unit will energize in **AUTO** mode. If the external controls are calling for a motor run condition, the motor will start. Make sure either external controls are off before energizing the input, or as soon as the unit has initialized, push the **STOP/OFF** key until **OFF** appears on the display. Refer to **Section 4**, pg. 16, *Using the Keypad and Display*, for instructions on operating the keypad.

## Drive Set-up Procedure

If remote or automatic ON/OFF function is required, connect remote switch leads to the **AUX1** and **COM** terminals. An additional remote switch may be connected to the **AUX2** and **COM** terminals. **AUX2 SELECT** must be set to 0 to use an additional switch.

**CAUTION:** When **SYSTEM CONFIG** = 1 (Digital CP), **AUX1** is programmed such that **OPEN=STOP**, **CLOSED=RUN** and **AUX2** is programmed such that **OPEN=RUN**, **CLOSED=STOP**. When **SYSTEM CONFIG** = 2 (Analog CP), **AUX1** and **AUX2** are programmed such that **OPEN=RUN**, **CLOSED=STOP**. See parameters **AUX1 SELECT** and **AUX2 SELECT** to change this setting.

1. If a Constant Pressure (CP) water system will be operated, connect the pressure sensors to the appropriate Control Terminals. See **Section 6.5**, pg. 38, *System Configuration* and **Section 7**, pg. 39, *Constant Pressure Systems* for details.
2. Apply power to the input terminals of the drive by turning on the input circuit breaker or disconnect switch.
3. The graphic text display will scroll through several start-up sequence messages.
4. If the **ENABLE RESTARTS** parameter is set to allow restarts, the drive will initialize in AUTO mode and the motor will run when control signals call for a motor run condition. In order to prevent the motor from running at start-up, immediately after initialization, press the OFF/STOP key until **OFF** appears on the display or open AUX1 or AUX2.
5. Confirm that the unit has properly energized, and the display indicates the OFF mode.
6. Using the keypad and display, navigate to the Main Menu item, **CHANGE PARAMETER VALUES**, to set the following parameters for basic operation (see **Table 12 - Table 13**, pg 26-28 for details).
7. **INTERFACE PARAMETERS > SYSTEM CONFIG** This parameter is critical to the operation of the system. The default setting is for simple ON/OFF operation. See **Section 6.5**, pg. 38, *System Configuration*, for complete information.
8. **OPERATING PARAMETERS > OVERCURRENT LIMIT** This parameter sets the motor overload protection. See **Section 6.2**, pg. 35, *Motor Overload Protection* for complete information.
9. **AUTO RESTART PARAMETERS > ENABLE RESTARTS** This parameter enables the drive to initialize in AUTO mode and to restart automatically after a fault. Factory default allows auto restarts.
10. Push the MANUAL key until **MANUAL** appears in top left of the display for manual mode, then push RUN to start the motor. In manual mode, the RUN/AUTO key will override an open AUX terminal or other external control signal. Push the STOP/OFF key to stop the motor in manual mode.



**CAUTION:** In manual mode, pushing the RUN key will override all external control signals, including constant pressure sensors. Be aware; ***dangerous pressure rise in closed plumbing systems is possible when running in manual mode.***

11. The motor will start with the default acceleration ramp time of 0-35 Hz, then 30-60 Hz in ten seconds.
12. After initial power-up, use the keypad and display to navigate to **CHANGE PARAMETER VALUES** to set any other adjustable parameters you wish to be different from the factory defaults.

### 6.3 Dry Well/Deadhead Protection & Low Production Well Control

The following parameters allow the drive to be programmed to protect the pump from dry run/deadhead conditions and to better perform in low producing well conditions.

|                  |                 |                   |
|------------------|-----------------|-------------------|
| DRY WELL CURRENT | RESTART DELAY 2 | RESTARTS DRY WELL |
| DRY WELL DELAY   | ENABLE RESTARTS |                   |

In water well pump applications it is important to protect the pump from dry run condition by setting the **DRY WELL CURRENT** parameter (found under **OPERATING PARAMETERS**) so that the drive stops and registers an underload fault in the Fault Log. **DRY WELL DELAY** can be programmed to auto restart after a delay to allow time for the water level to recover. The number of restarts allowed can be programmed through the **RESTARTS DRY WELL** parameter. The Fault Log allows the user to monitor the type and number of faults that have occurred. If the number of dry well faults exceeds the number of automatic restarts allowed for that fault, the drive will remain OFF until the Fault Log is cleared, which resets ALL resettable fault counters. See Auto Restarts in **Section 5.3**, pg. 24, for more information.

### 6.4 Motor Overload Protection

AutoDRIVE VFDs are equipped with adjustable solid state motor overload protection. Protection is based on a Class 10 trip curve. Motor overload settings are selected by navigating to the appropriate menu item using the keypad and display.

#### Thermal Memory and Thermal Memory Retention

The motor overload protection is equipped with thermal memory and thermal memory retention capabilities.

**THERMAL MEMORY** is the ability of an overload protective system to approximate the heating cooling of a protected motor during operation.

**THERMAL MEMORY RETENTION** maintains the thermal memory upon shutdown or power loss. This includes retention of the last thermal value, and may include an ongoing reduction of this thermal value to reflect the cooling of the motor. This information will be used by the overload protective system to approximate the thermal state of the motor upon restart.



**CAUTION:** Do not attempt to restart the motor immediately after a motor overload fault. The motor overload protection system uses a timer to approximate motor cooling and may trigger an immediate overload fault if the motor is restarted too soon.

#### Setting Motor Overload Protection with Keypad

To set motor overload protection with the keypad, navigate to the Main Menu item **CHANGE PARAMETER VALUES > CHANGE OPERATING PARAMETERS > OVERCURRENT LIMIT**. Refer to **Section 4.5**, pg. 18, *Changing Parameter Values*, **Table 12**, pg. 26, *Operating Parameters* for detailed instructions.

## 6.5 System Configuration

AutoDRIVE VFDs are capable of operating several types of systems, including constant pressure water systems, with simple ON/OFF control from remote switches. **The correct system configuration must be selected for proper operation of different types of control systems.**

System configuration is set by navigating to the keypad Main Menu item **CHANGE PARAMETER VALUES > CHANGE INTERFACE PARAMETERS > SYSTEM CONFIG**. Below is a brief description of each configuration setting:

- **System Configuration = 0: Basic RUN/STOP operation.** This is the factory default configuration for basic operation of the drive that allows RUN/STOP control of the motor in AUTO mode using a dry contact on AUX1 and/or AUX2.

**! CAUTION:** By default, **AUX1** is programmed such that **OPEN=STOP, CLOSED=RUN** and **AUX2** is programmed such that **OPEN=RUN, CLOSED=STOP**. When **SYSTEM CONFIG = 2 (Analog CP)**, **AUX1** and **AUX2** are programmed such that **OPEN=RUN, CLOSED=STOP**. See parameters **AUX1 SELECT** and **AUX2 SELECT** to change this setting.

**System Configuration = 1: Digital Constant Pressure.** Use this setting to operate digital constant pressure systems. Only use digital pressure switches purchased from or approved by A.Y. McDonald. Refer to **Section 7.3**, pg. 42, Digital Constant Pressure Systems, for more information on operating the drive in this mode.

**System Configuration = 2: Analog Constant Pressure.** Use this setting to operate analog constant pressure systems with a 4-20 mA transducer. Refer to **Section 7.5**, pg. 44, Analog Constant Pressure Systems, for more information on operating the drive in this mode. Refer to **Figure 9**, pg. 14, for a diagram illustrating connection of the transducer to Control Terminals. If a redundant analog transducer is used, connect it to the I2+ and I2- Terminals in likewise fashion. If the sensor on I1 fails (current signal is zero) the drive will look for a signal on I2 to control pressure. If there is no signal on I2 the drive will stop and indicate **SENSOR CONNECTION FAIL**.

**System Configuration = 3: 0-5 VDC Speed Control.** Use this setting to control speed using a 0-5 VDC potentiometer. Speed is relative to scale of signal from 0 Hz to **MAX FREQUENCY**. Refer to **Figure 10**, pg. 15, for a diagram illustrating connection of potentiometer.

**! CAUTION:** This is not a constant pressure control mode. Motor speed will be controlled in a linear fashion proportional to the analog signal.

The System Configuration must be in any of the constant pressure modes to enable Pre-Charge of the plumbing system. See **Section 7.7**, pg. 47, *Pre-Charge* for more information.

## 6.6 Start-Up and Shut-Down Ramp Times

Start-up and shut-down ramp times specify the time required to go from Minimum Frequency to Maximum Frequency or vice versa. Ramp times and profiles are adjustable by changing Operating Parameters through the keypad and text display. Factory settings activate the **COAST TO STOP** parameter to reduce nuisance tripping from high inertia loads. Coast to stop inactivates the **SHUTDOWN RAMP** parameter.

To help protect submersible pumps from damage at startup, the ramp time from 0-35Hz is fixed at 1 sec.

## 7 CONSTANT PRESSURE SYSTEMS

AutoDRIVE VFDs can be configured as constant pressure (CP) water systems to maintain a constant pressure under variable flow conditions. A CP water system includes a pressure tank, a pressure gauge to observe system pressure, and either a digital pressure switch or a 4-20 mA analog pressure sensor.

### 7.1 Control Principles of Constant Pressure Systems

In a CP system, a target pressure for the system is set through the keypad. A signal from the pressure sensor interacts with firmware in the drive controller to control the motor speed and maintain a constant water pressure.

In a strict definition of a CP system, the pump would never turn off. If the pressure differential between pump-on and pump-off was actually zero, the noise fluctuations of the sensor output would cause the motor to cycle constantly between the on and off states. For this reason, most applications will want to accept a small differential pressure in the system in order to prevent either continuous running of the motor, or constant on/off cycling of the motor.

Three basic conditions must be met for the pump to shut down and enter sleep mode:

1. The pressure in the system must be at the pressure control point set by the parameter **psi SETPOINT**.
2. The pump speed has slowed to a frequency below the value determined by **SHUTOFF FREQ + MIN FREQ**. For example, if **SHUTOFF FREQ** is 10 and **MIN FREQ** is 30, the pump will enter sleep mode at 40 Hz.
3. The time expired since the pump started after the last OFF cycle must be greater than parameter **T1 On** or **T2 On**.

If the system pressure goes above the parameter **OVERPRESSURE psi** the pump will immediately shut down. **OVERPRESSURE psi** is equal to **psi SETPOINT** plus **OVERPRESSURE psi**. For example, if **psi SETPOINT** is 50 and **OVERPRESSURE psi** is 20 the pump will shut down at 70 psi.

#### Disable Sleep Mode

In some applications the user may choose to prevent the pump from entering sleep mode. This is accomplished by setting the parameter **SHUTOFF FREQUENCY** to a value of zero. In low or no flow conditions the pump will slow to the speed determined by **MIN FREQUENCY** and remain at that speed indefinitely.



**CAUTION:** When sleep mode is disabled in low flow conditions, the drive will slow down to minimum frequency and continue to run. Inadequate water flow in this condition may overheat and damage the pump.

#### Preventing Short Cycling During Low Flow Conditions

When a CP system is in a low flow state, it may be desirable to turn the motor off (sleep mode) in order to conserve energy and preserve the motor. The adjustable parameters **T OFF**, **T1 ON**, **T2 ON**, **SHUTOFF FREQUENCY**, **OVERPRESSURE psi**, **DRAWDOWN psi**, and **BOOST AMOUNT** control when the motor is turned off, how long it is off, and also prevent short cycling of the motor at low water flow rates. More information including default values for these parameters can be found in **Table 15**, pg. 31-32, *Constant Pressure Parameters*.

## DRAWDOWN psi and BOOST AMOUNT

The primary method of preventing short cycling is to allow a differential between the pressure at which the pump turns off to enter sleep mode and the pressure at which it restarts. Two parameters, **DRAWDOWN psi** and **BOOST AMOUNT**, control this differential. **BOOST AMOUNT** specifies the increase in pressure above **psi SETPOINT** just before the pump shuts down to enter sleep mode, while **DRAWDOWN psi** specifies the pressure drop below **psi SETPOINT** at which the pump restarts. For example, assume **psi SETPOINT** = 50, **BOOST AMOUNT** = 5, and **DRAWDOWN psi** = 5. When the pump is ready to enter sleep mode, the pump will boost to 55 psi, then restart when the pressure falls to 45 psi. These two parameters can be used together or independently to create a dead band in pressure control.

Both **OVERPRESSURE psi** and **SHUTOFF FREQUENCY** cause the drive to enter sleep mode. **OVERPRESSURE psi** is additional system protection. It is a value that is added to the **psi SETPOINT**. The default value for **OVERPRESSURE psi** is 20. For example, if the **psi SETPOINT** is 50 psi, the drive will stop the motor if pressure reaches 70 psi.

The parameter **SHUTOFF FREQUENCY** is used to put the drive in sleep mode when pressure is controlled and flow is low. Shut off frequency is a value that is added to **MIN FREQUENCY**. For example, if minimum frequency is 30 Hz and shut off frequency is 12, the drive will enter sleep mode at 42 Hz. When a value of zero is entered for the parameter **SHUTOFF FREQUENCY**, sleep mode is disabled.



**CAUTION:** When sleep mode is disabled in low flow conditions, the drive will slow down to minimum frequency and continue to run. Inadequate water flow in this condition may overheat and damage the pump.

## ON/OFF Cycle Timers

The drive records the length of time the motor remained in the OFF cycle and compares that time to the parameter, **T OFF**. If the motor-off time during the last OFF cycle was greater than the value of **T OFF**, then the minimum motor-on time will be equal to **T1 ON**. If the motor-off time was less than **T OFF**, the minimum motor-on time will be equal to **T2 ON**.

In other words, the time of the last OFF cycle determines whether the next ON cycle should be relatively long or relatively short. The graphic in **Figure 15**, pg. 40, demonstrates how the system adjusts the motor-on time in response to motor-off time.

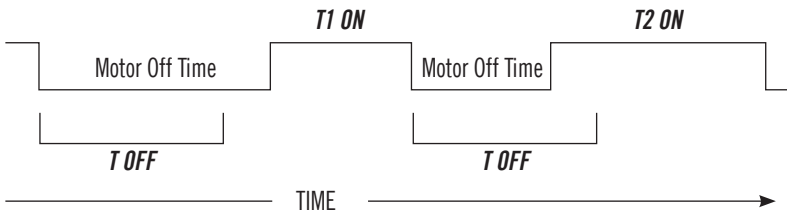

Figure 15 – Motor On and Off Times



## Fine Tuning With PI Control

When operating in constant pressure mode, if the parameter **PROPORTIONAL GAIN** is set to a value less than 1, the keypad displays **SIMPLE MODE** and the controller uses an algorithm that is not PI control. Simple Mode requires less fine tuning than PI control, but in some applications may not provide the control and stability desired. The stability of the constant pressure system (i.e., its tendency not to exhibit pressure oscillations) is determined by parameters set on the keypad, the flow rate of the pump, and the volume of the pressure tank. Stability of a system with a large maximum flow rate and a small pressure tank will be more difficult to control and may require de-tuning the system to accept larger variations in the system pressure and longer response times. Analog constant pressure systems with PI (proportional integral) control provide more options to fine tune pressure control than Simple Mode. Systems that are not adequately controlled with the Simple Mode may require fine tuning by switching to PI control. Increasing the value of **PROPORTIONAL GAIN** to any value greater than **SIMPLE MODE** will initiate PI control. Pressure control is achieved by adjusting the values of **PROPORTIONAL GAIN** and **INTEGRAL GAIN**. Larger values for **PROPORTIONAL GAIN** and **INTEGRAL GAIN** give smaller error in the pressure, but also make the system more susceptible to oscillation. The following pages of this Section will provide more information on tuning PI control.

### Emergency Over-Pressure Limit Switch

Constant pressure systems have the option of connecting an emergency over-pressure limit switch to the AUX2 terminals in case the main pressure control system fails. The emergency over-pressure set point should be at least 10 psi higher than the system control pressure to prevent nuisance tripping.



**CAUTION:** By default, **AUX1** is programmed such that **OPEN=STOP, CLOSED=RUN** and **AUX2** is programmed such that **OPEN=RUN, CLOSED=STOP**. When **SYSTEM CONFIG = 2** (Analog CP), **AUX1** and **AUX2** are programmed such that **OPEN=RUN, CLOSED=STOP**. See parameters **AUX1 SELECT** and **AUX2 SELECT** to change this setting.

## 7.2 Digital Pressure Switch

AutoDRIVE model SD1-2HP2PS comes standard with a pressure switch set to 60 psi. The pressure set point can be adjusted by removing the protection plug and using a 5mm Allen wrench to turn the screw. See **Figure 16** to identify the protection plug. Turning the screw clockwise will increase the pressure set point and turning the screw counterclockwise will decrease the pressure set point. The operating pressure range is 25 psi – 150 psi. Run the pump in AUTO mode, and observe the pressure gauge, turning the Allen screw to adjust the pressure set point.

**Figure 16 – Pressure Switch**

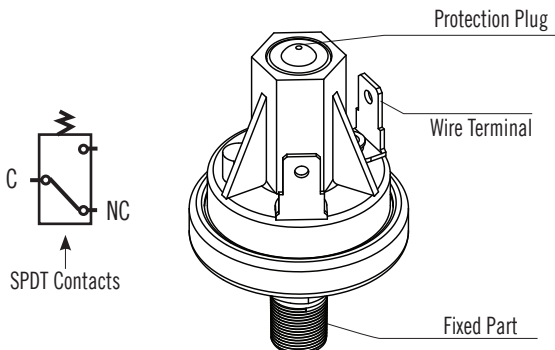

## 7.3 Digital Constant Pressure Systems

For digital CP systems, the factory default settings will be satisfactory for most CP applications. When running in digital CP, the digital pressure switch only supplies the drive with an open or closed signal, so the drive will not display pressure on screen.

### Adjusting Parameters in Digital CP Systems

Using the keypad, there are several parameters which can be adjusted to fine tune digital CP systems. These are **MAX FREQUENCY**, **MIN FREQUENCY**, **T OFF**, **T1 ON**, **T2 ON**, **SHUTOFF FREQUENCY**, and **BOOST AMOUNT**. The use of these parameters has been discussed in the previous section. **Table 15**, pg. 31-32, provides more detail.

### Digital Constant Pressure Installation Procedures:

1. Install the digital pressure switch (included with the SD1-2HP2PS) in the water line



**Control Tip:** Turbulence near pressure switch or transducer can result in poor pressure control. For best results, pressure switches and transducers should be placed at least 6 inches away from pressure tanks, check valves, and pipe elbows.

2. Install spade terminals, on provided pressure switch wire, to the Normally Closed (NC) and Common (COM) terminals of the digital pressure switch.
3. Install other end of pressure switch wires to AUX1 and COM ports on control board. Cut sensor cable to length, if necessary.
4. Install rubber boot over pressure switch.
5. Attach cable shield to the Control Terminal Ground. See **Figure 5**, pg. 10, for location.
6. Adjust the pressure set point by following the steps in **Section 7.2**, pg. 41.
7. Navigate through the keypad Main Menu item **CHANGE PARAMETER VALUES > INTERFACE PARAMETERS > SYSTEM CONFIG**. Select **1** to set the system configuration for a digital CP system.

### Digital Overpressure Switch Installation and Programming:

8. If using an emergency over-pressure limit switch, connect it between AUX2 and COM (common). Then navigate to **CHANGE PARAMETER VALUES > INTERFACE PARAMETERS > AUX2 SELECT** and set this parameter to **0** (closed = RUN, open = STOP). To set the emergency over-pressure limit switch, follow the steps in **Section 7.2**, pg. 41.



**CAUTION:** The emergency over-pressure limit switch should be set at least 10 psi higher than the desired constant pressure set point.

9. Set the keypad to AUTO mode to operate the system.

**Figure 16 – Digital Constant Pressure Diagram**

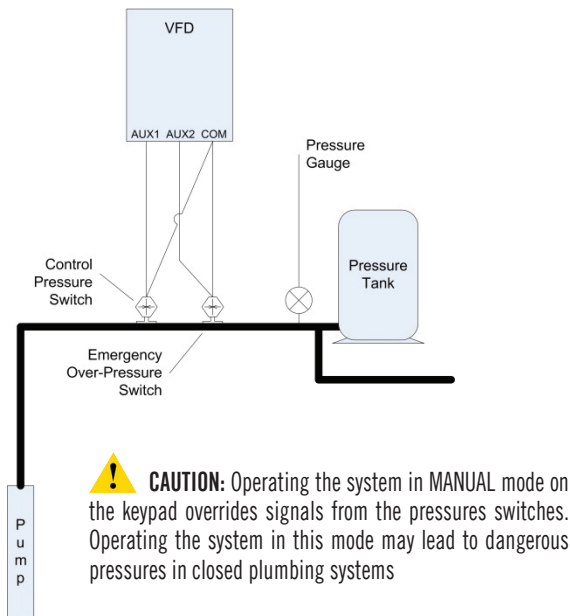

## SIMPLE MODE Control

A.Y. McDonald has developed a proprietary controller which involves fewer parameters to tune constant pressure performance. When the **PROPORTIONAL GAIN** parameter is set at the lowest value, the display will read **"SIMPLE MODE"**. In **SIMPLE MODE** a set of control equations are used which may not require the user to tune the system to obtain acceptable performance.

A well-tuned PI controller will result in smoother pressure control but may not be required. When the controller is in simple mode the only parameters which affect the pressure control loop are the **psi SETPOINT**, **STARTUP RAMP**, **SHUTDOWN RAMP** and **BOOST AMOUNT**, which function in the same way as they do in the PI control mode. Adjusting ramp times may smooth out any oscillation or overshoot in simple mode. If pressure is not adequately controlled, switch to PI control by increasing parameter **PROPORTIONAL GAIN**.

## Using PI Control in Constant Pressure

When using an analog pressure transducer for control in constant pressure water systems, it may be desirable to use a proportional-integral (PI) controller in the feedback loop. This type of controller has a proportional gain and integral gain which can be tuned by the user to obtain optimum performance for each particular application. Increase parameter **PROPORTIONAL GAIN** to switch control from Simple Mode to PI control. It is recommended to start with a parameter value of 5. A proportional gain value too low will result in slow response time to reach the psi setpoint. A value too high will result in overshoot of the psi setpoint and may create excessive oscillation of pressure.

First, attempt to control pressure by adjusting parameter **PROPORTIONAL GAIN**, leaving parameter **INTEGRAL GAIN** at the default value of 15. If adequate control cannot be obtained by adjusting proportional gain, set proportional gain at the value that gives the best control, then adjust integral gain to improve pressure control.

For difficult-to-control systems, a derivative term can be introduced for PID control, which can help control pressure oscillation and overshoot. Increase the value of parameter **DERIVATIVE GAIN** to a value greater than zero to enable PID control. This parameter should be used only when necessary as it tends to amplify noise in the transducer signal. The system may become unstable. The parameters **PID FILTER GAIN** and **PID FILTER TIME** help to prevent overshoot. It may be advisable to contact the factory for assistance when using PID control for the first time.

In conceptual terms, proportional gain affects how quickly the system responds to pressure changes and integral gain affects the accuracy of pressure tracking. Adjusting ramp times can also be considered. Increasing ramp time will damp response to pressure changes, while decreasing ramp time will quicken the response.



**CAUTION:** Long ramp times can interfere with PI control of constant pressure. It is advisable to start with factory default ramp times.

## Pressure Control at Minimum Speed

There is a possibility of conflict between the minimum pump speed setting, controlled by the parameter **MIN FREQUENCY**, and the pressure setting of the transducer. That is, if under no-flow conditions the pump at its minimum speed setting produces a pressure greater than the desired set-point, either the minimum speed will have to be reduced or the pressure set-point will have to be increased. Most pumps should not produce enough pressure head at 35Hz for this to be an issue.

## 7.4 Constant Pressure Setup

Upon the first initialization of the unit (or after restoring factory defaults of all parameters using the two-button reset procedure, page 23) the drive will enter into a set of questions in order to setup the constant pressure system. Basic parameters for analog or digital constant pressure can be set without navigating through the complete menu options. For a flow chart of these questions see page 33.

**Pressure Sensor Type** – Use this parameter to select **Pressure Switch**, **Pressure Transducer**, **Speed Pot**, or **No** to determine how the drive will control the motor. (Single Phase Only)

**Motor Type** – Use this parameter to select either **2 Wire Motor** or **3 Wire Motor**. 2-wire motors have a start capacitor built into the motor while the 3-wire motors utilize a start capacitor in the drive. (Single Phase Only)

**Motor Manufacturer** – This allows the user to select either **A.Y. McDonald** or **Other** as the manufacturer. This selection tunes the motor phase angle, which changes from manufacturer to manufacturer. (Note: If other is chosen, there are more manufacturer options in the drive's main menu. If your motor manufacturer is not listed, contact the factory). (Single Phase Only).

**psi Setpoint** – Use this parameter to select the pressure for the system. (Analog Transducer Only)

**Service Factor Amps** – Use this parameter to set the motor overload protection level (use the service factor max amps rating for the motor)

This quick setup of constant pressure should provide good pressure control in most situations. It is advisable to read the entire section on constant pressure control for a complete explanation of constant pressure control methods. Refer to **Table 15**, pg. 31-32, **Constant Pressure Parameters**, for expanded menu options to fine tune the constant pressure system.

## 7.5 Analog Constant Pressure Systems

The analog CP system uses an analog pressure transducer connected to the analog input (I\_1+ and I\_1-) on the Control Terminals (see **Figure 9**, pg. 14 and **Figure 17**, pg. 45 for wiring diagram and one-line diagram). A normally closed emergency overpressure switch connected to the AUX2 terminals is also recommended. If an overpressure switch is used, **AUX2 SELECT** must be changed to 0. These are used in conjunction with the internal firmware of the drive to implement a constant pressure water system.

The drive uses a proportional-integral (PI) or proportional-integral-derivative (PID) controller in the feedback loop for constant pressure control. This type of controller has a gain adjustment which must be tuned by the user to obtain optimum performance for each particular application. A.Y. McDonald has also developed a proprietary controller, Simple Mode, which requires minimal tuning. When the **PROPORTIONAL GAIN** parameter is set at the lowest value, the display will read **"SIMPLE MODE"**.

In Simple Mode a set of control equations is used which usually requires minimal tuning of the system to obtain acceptable performance. A well-tuned PI or PID controller will give smoother pressure control and may be necessary to control unstable systems. When the controller is in Simple Mode, the only parameters which affect the pressure control loop are **psi SETPOINT**, **STARTUP RAMP**, **SHUTDOWN RAMP** and **BOOST AMOUNT**.

In PI control mode the analog signal from the pressure transducer is compared to the parameter **psi SETPOINT**, which controls the motor speed to maintain constant pressure in the system. In this control scheme, the error signal between the pressure transducer and the internal signal determined by the **psi SETPOINT** value is multiplied by the **PROPORTIONAL GAIN**. This signal is then used to determine the motor frequency. If the pressure transducer signal and the internal set-point value were the same, then the motor speed would be zero. High **PROPORTIONAL GAIN** and **INTEGRAL GAIN** values give smaller error in the pressure, but also make the system more susceptible to oscillation.

Additional adjustable parameters, in the Constant Pressure menu, can help to optimize the performance of the system. The use of these parameters was discussed in the previous section. The unit is shipped with default settings which will work in many applications with no adjustment. As with any system, there are tradeoffs between maintaining a tightly controlled set-point, achieving high motor efficiency, and maintaining system stability.

Figure 17 – Analog Constant Pressure One-Line Diagram

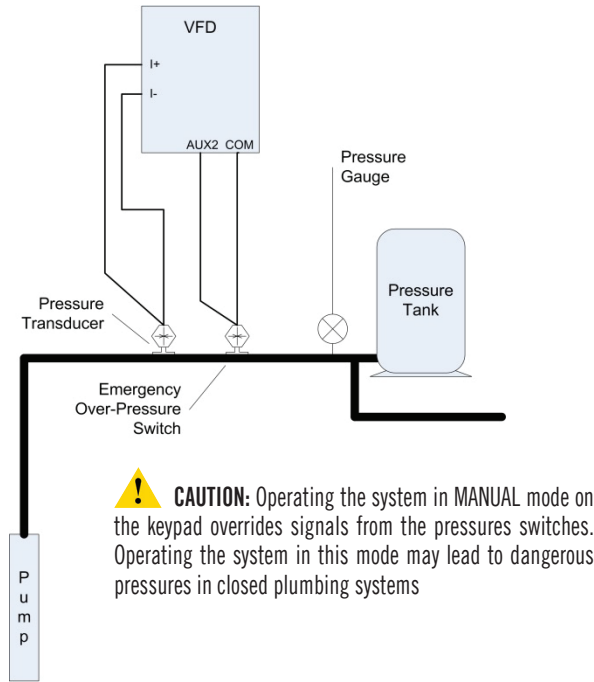

**CAUTION:** Operating the system in MANUAL mode on the keypad overrides signals from the pressure switches. Operating the system in this mode may lead to dangerous pressures in closed plumbing systems

## 7.6 Basic Analog Constant Pressure Installation Procedures:

1. Install the analog pressure transducer and emergency over-pressure switch in the water line



**Control Tip:** Turbulence near pressure switch or transducer can result in poor pressure control. For best results, pressure switches and transducers should be placed at least 6 inches away from pressure tanks, check valves, and pipe elbows.

2. Remove protective rubber boot from the over-pressure switch, insert factory provided duplex cable through the boot, and connect a twisted pair of wires to the normally closed (NC) and common (C) terminals of the switch



**CAUTION:** The use of shielded cable is recommended. Regular wire may induce capacitance in the line and corrupt the signals from the pressure switches.

3. Attach the cable shield to the Control Terminal Ground post located next to the Control Terminals. See **Figure 6**, pg. 11 for terminal locations.
4. Connect the emergency over-pressure limit switch to the AUX2 Control Terminal and COM (common).

**!** **CAUTION:** By default, **AUX1** is programmed such that **OPEN=STOP, CLOSED=RUN** and **AUX2** is programmed such that **OPEN=RUN, CLOSED=STOP**. When **SYSTEM CONFIG = 2** (Analog CP), **AUX1** and **AUX2** are programmed such that **OPEN=RUN, CLOSED=STOP**. See parameters **AUX1 SELECT** and **AUX2 SELECT** to change this setting.

5. Navigate through the keypad Main Menu item **CHANGE PARAMETER VALUES > INTERFACE PARAMETERS > SYSTEM CONFIG**. Select **2** to set the system configuration for an analog CP system (see **Table 15**, pg. 31-32 for details). (Single Phase Only).
6. To set the emergency over-pressure limit switch, remove the rubber boot from the switch and pry the plastic plug from the top of the switch housing to access the pressure adjustment screw. Use an Allen wrench to adjust the pressure setting of the switch and run the pump in the AUTO mode, and observe the pressure gauge, turning the Allen screw to adjust the pressure shut-off point. **The emergency over-pressure limit switch should be set at least 10 psi higher than the desired constant pressure set point.**
7. Connect the positive terminal of the transducer to the I+ Control Terminal, and the negative terminal to the I- Control Terminal.

**!** **CAUTION:** It is critical that the positive terminal of the transducer is connected to the (+) terminal of the 4-20 mA control terminal and that the negative terminal of the transducer is connected to the (-) terminal of the 4-20 mA control terminal.

8. Set the **psi SETPOINT** on the keypad (see **Table 15**, pg. 31-32, *Constant Pressure Parameters* for details)
9. Set the keypad to AUTO mode to operate the system

## 7.7 Pre-Charge Mode

When filling a large plumbing system with water, it may be desirable to fill at a slow pump speed so that when the system reaches the full point, water hammer does not cause damage such as sprinkler head blow-off or burst pipes. To achieve this, the drive is equipped with a pre-charge feature.

This feature is disabled if the **PRECHARGE TIME** parameter is set to zero. The frequency of the pump will not exceed the value set by the **PRECHARGE FREQ** parameter during the pre-charge interval.

The pre-charge interval will terminate when the system pressure exceeds the setting of the **PRECHRG psi** parameter. In this case, the **PRECHRG psi** must be lower than the psi **SETPOINT**.

The pre-charge interval occurs whenever the drive is switched from OFF to AUTO or MANUAL > RUN.

### Pre-charge Mode Setup:

1. Navigate through the keypad menu to:  
**CHANGE PARAMETER VALUES > CONSTANT PRESSURE PARAMETERS > PRECHARGE FREQ**  
Enter the Pre-charge frequency
2. Navigate through the keypad menu to:  
**CHANGE PARAMETER VALUES > CONSTANT PRESSURE PARAMETERS > PRECHARGE TIME.**  
Enter the Pre-charge time in minutes

3. Navigate through the keypad menu to: **CHANGE PARAMETER VALUES > CONSTANT PRESSURE PARAMETERS > PRECHRG psi**.  
Enter the pre-charge pressure in psi. This value must be lower than the **psi SETPOINT**
4. Set the keypad to AUTO mode to operate the system

## 7.8 Tank Sizing

For constant pressure systems, a pre-charged pressure tank should be used. The tank should be at least 20% of the pump's rated flowrate in Gallons Per Minute (GPM). For instance, a pump rated 10 GPM requires at least a 2-gallon tank.

## 7.9 Troubleshooting Constant Pressure Systems

A variety of conditions in a plumbing system can lead to less than optimum performance of constant pressure control while using the factory default settings. The default settings are designed to operate a range of plumbing systems, but there can be many variables in a plumbing system that requires adjustment of the constant pressure parameters.

In order for the drive to enter sleep mode while operating in constant pressure mode, three conditions must be met:

1. The pressure in the system must be at the pressure control point set by the parameter **psi SETPOINT**.
2. The frequency declines to the shut off frequency (defined as **MIN FREQUENCY** plus **SHUTOFF FREQUENCY**).
3. The time expired since the pump started after the last OFF cycle must be greater than parameter **T1 ON** or **T2 ON**

When these conditions have been met, the drive will go to sleep. The duration of which the drive is asleep depends on the rate at which the system bleeds down and the width of the dead band. When setting and testing a constant pressure system, try to operate as close as possible to the normal operating conditions. Low flow in a high capacity system (and vice versa) usually requires some adjusting of the parameters.



## 8 TROUBLESHOOTING

This section provides information on fault codes and troubleshooting tips for potential system problems.

 **WARNING!** In some instances, the unit will shut down, then automatically restart when conditions allow. Always disconnect input power from the unit and wait for internal electrical charges to dissipate before performing service on the unit or its connected loads.

 **WARNING:** Risk of electric shock. De-energize the unit by disconnecting all incoming sources of power, then wait 10 minutes for internal charges to dissipate before servicing the equipment.

 **HIGH VOLTAGE:** This equipment is connected to line voltages that can create a potentially hazardous situation. Electric shock could result in serious injury or death. This device should be installed and serviced only by trained, licensed and qualified personnel. Follow instructions carefully and observe all warnings.

Always check the LCD display for fault codes if the drive or its load is not operating. Disconnecting the input power could potentially clear any fault code indication, possibly losing valuable information for troubleshooting.

### 8.1 Fault Codes

Fault codes are indicated on the graphic display. See **Table 16**, pg. 50, for a list of fault codes.

The drive can be programmed to automatically restart after certain faults and a time delay can be programmed before the restart is allowed. To interrupt a time delay countdown and allow auto restart, press both arrow keys on the keypad and hold for one second. The load will start immediately. The Restart Log is a resettable fault log that can be used to monitor faults that allow auto restart. Use the Clear Memory function to reset the Restart Log and set all fault counters to zero. See **Section 4.4**, pg. 17, *Keypad Main Menu Items*, for more information on Restart Log and Clear Memory function.

 **WARNING:** Certain faults do not allow an auto restart. These faults generally indicate the possibility of damage to the drive and/or the load, or indicate the possibility of a dangerous condition. When this type fault occurs, the display will read **NO AUTO RESTART**. Refer to **Table 16**, pg. 50, Fault Codes, to determine if the fault allows an auto restart. The number 1 in the notes column indicates that auto restart is not allowed. When this type of fault occurs, contact the factory for assistance before restarting or troubleshoot the system thoroughly. These faults can be cleared only by cycling input power OFF/ON.

 **WARNING:** Unit may restart automatically without warning after a fault when operating conditions permit. Make certain input power is disconnected before servicing the unit or its connected loads.

#### Clearing a Fault

If the unit is programmed to automatically restart after a particular fault, the display indicates that the unit will restart and will count down the seconds remaining to restart on the display. The countdown can be interrupted by pressing and holding both arrow keys. The load will immediately restart.

For faults that allow an automatic restart, the default number of restarts after a fault is zero. If the end user desires the unit to automatically restart after a fault, the number of restarts allowed and the time between fault and restart must be programmed in the **CHANGE PARAMETER VALUES > AUTO RESTART PARAMETERS** for that fault.

If the drive has exceeded the programmed number of auto restarts, or if auto restarts have not been enabled, the display will indicate the fault on the top line and the second line will read **RESTART? ENTER**. Press ENTER to clear the fault and restart the load. The fault counters in the Restart Log will all be reset to zero. See **Section 4.9**, pg. 22, Restart Log, for more information.

The **ENABLE RESTART** parameter allows the drive to restart automatically after a fault. This parameter also enables the drive to initialize in AUTO mode when the input power has been cycled OFF/ON and the drive is energized. The factory default setting does not allow auto restarts. Navigate to this parameter via **CHANGE PARAMETER VALUES > AUTO RESTART PARAMETERS > ENABLE RESTART**.

There are several conditions where the drive will indicate a fault but the fault will not be recorded in the fault log. These faults occur only when the drive is energized from utility mains and is initializing. If any of three conditions including ground fault, high input voltage or low input voltage is detected, the display will indicate the fault and wait for the condition to resolve before entering normal operating mode. If these conditions occur after the drive has initialized, a fault will be logged and can be cleared in the normal manner.

**Table 16 – Fault Codes**

| Text Message       | Description / Comments  | Notes |
|--------------------|---|-------|
| OUTPUT FAULT       | Check for short circuit on output lines and load. Contact factory   | 1     |
| OVER TEMPERATURE   | Internal temperature of the switching modules exceeded safe limits. Check fans and ventilation openings for obstruction. Reduce ambient temperature.  | 2     |
| BUS OVERVOLTAGE    | Sudden and severe regenerative power under high line voltage conditions may result in bus overvoltage. Check line voltage or consider increasing ramp up and ramp down times.   | 2     |
| PRECHARGE FAIL     | DC bus voltage did not reach normal level. Possible failure of input modules or pre-charge circuit.   | 2     |
| HIGH INPUT VOLTAGE | Input voltage has exceeded a level for safe operation. Reduce input voltage. General purpose buck/boost transformers are compatible with AutoDRIVE VFDs.  | 2     |
| MOTOR OVERLOAD     | Output current has exceeded the value set for <b>SERVICE FACTOR AMPS</b> in OPERATING PARAMETERS menu. Check status of motor load. If output current limit is increased, make sure it is within the limit of the motor nameplate. Automatic restarts are set by <b>RESTART DELAY 1</b> in the AUTO RESTART PARAMETERS menu. | P, 2  |
| DRY WELL CURRENT   | Motor current fell below the value set in <b>DRY WELL CURRENT</b> under OPERATING PARAMETERS menu. Used to detect dry well condition.   | P, 2  |

| Text Message           | Description / Comments   | Notes |
|------------------------|--|-------|
| OUTPUT OVERLOAD        | Indicates a large and sudden overcurrent event on the output module. Check the motor circuit for faults. Sudden changes in the load may also have occurred such as the closing of a relay that results in an across-the-line start of a motor. Never install relays in the motor circuit.  |       |
| LOW INPUT VOLTAGE      | Input voltage has fallen below a level for safe operation of the drive.  | 2     |
| GROUND FAULT           | A fault between an output line and earth has been detected. Immediately disconnect input power and check output lines with a megger to verify a fault. Nuisance trip is a possibility. Sensitivity of fault detection can be adjusted by the Operating Parameter <b>GND FAULT DETECT</b> . See <b>Table 12</b> , pg. 26 for details. | 1     |
| SENSOR CONNECTION FAIL | Indicates open circuit. 4-20mA analog signal is not present on Control Terminals I+ and I-. This could indicate failure of the 4-20mA sensor or that the cables from the sensors have been disconnected. Only in Analog CP.  | 2     |
| 15V DC POWER OVERLOAD  | Indicates closed circuit. Check for short circuit between lines. Check the polarity of the wires on I+ and I-. Only in Analog CP. System may also say <b>OVERPRESSURE</b> .<br><br>Check the 4-20 mA reading under Read Measured Values. If the reading is considerably above 20 mA, the transducer terminals are shorted.           | 1     |
| BROKEN PIPE FAULT      | Pressure has fallen below the limits set for <b>BROKEN PIPE psi</b> for a length of time exceeding <b>BROKEN PIPE TIME</b> . Check for leaks or broken pipe.   | 1     |

P = Fault may be related to an adjustable parameter. Always check the value of the parameter to eliminate nuisance tripping.

1 = Drive has shut down due to a potentially dangerous condition. Drive will remain OFF until input power is cycled OFF/ON. Use caution if the drive is restarted.

2 =  **WARNING:** Auto restart allowed for this fault. Motor may restart automatically without warning after a fault when operating conditions permit. Make certain input power is disconnected before servicing the unit or its connected loads.

**Table 17 – Troubleshooting**

| Problem                  | Potential Cause                                     | Solution   |
|--------------------------|---|--|
| Motor not running        | Is a fault code indicated?                          | Resolve any factors likely causing the fault. Clear the fault by pressing both arrow keys on the keypad or by cycling input power OFF/ON.  |
|                          | Are the remote switches AUX1 and AUX2 closed?       | Check status of AUX1 SELECT and AUX2 SELECT. AUX terminals must match AUX inputs and system config settings. The LCD display indicates the status of AUX terminals in the default display mode.                        |
|                          | Are the signals to the Control Terminals corrupted? | Shielded cable is required for AUX terminal switch leads longer than 20 ft. Regular wire will induce capacitance in the line and corrupt control signals. Shielded cable is recommended for all Control signal cables. |
|                          | Is the keypad in MAN or OFF mode?                   | The keypad will override signals on the Control Terminals when OFF or MAN is selected. Keypad must be in AUTO mode for external control signals to control the motor.  |
|                          | Is the maximum frequency set at 0 Hz?               | Check the maximum frequency by using the keypad to navigate <b>MAIN MENU&gt;CHANGE PARAMETER VALUES&gt;OPERATING PARAMETERS&gt;MAX FREQUENCY.</b>  |
|                          | Are the input terminals energized?                  | Check that terminals have voltage. If not, check the main input fuses or breaker.  |
| Poor pressure regulation | Turbulence due to sensor location                   | Move pressure switch or transducer at least 6 inches away from pressure tanks, check valves, and pipe elbows.  |
|                          | <b>RESPONSE TIME</b> not optimized                  | Adjust <b>RESPONSE TIME</b> to tune system to site-specific configurations.  |

## 8.2 Routine Inspection and Maintenance

The unit should be inspected and cleaned at least annually or more frequently if it is in an excessively warm or dusty environment.

**Overall:** Perform a visual inspection checking for things such as discolored wires or terminals, evidence of arcing, loose mounting screws, physical damage to the enclosure, etc.

**Power terminals:** Inspect for loose connections and tighten to specifications in **Table 4**, pg. 9, Field Wiring Power Terminal Specifications.

**Capacitors:** Check for leakage or deformation.

**Fans and heatsinks:** Excessive dust buildup on the heatsink and cooling fan impellers may lead to overheating. Lightly brush and vacuum clean.

**Instructions for fan replacement:** Contact Customer Service for assistance in replacing the cooling fan in the event it should fail. Use only fans approved by A.Y. McDonald . Unapproved fans may not be able to move enough air to properly cool the unit, leading to component damage.





A.Y. McDonald Mfg. Co. is a leading manufacturer of Water Works, Plumbing, Pumps, and Natural Gas Products. The Company has distinguished itself with a proud tradition of quality and reliability since its founding in 1856.

The mission of A.Y. McDonald Mfg. Co., in the words of our founder, is “to make good products and sell them honestly.” We, the stockholders and employees, accomplish this by extending the McDonald family culture through excellent customer service and by focusing on our customers’ needs.

At A.Y. McDonald, you aren’t just getting a product; you are getting an innovative solution, access to educational opportunities, and the ability to be treated like family. The customer is the boss and we aim to break the mold on how we reach customer satisfaction. Because in the end, without you, there would be no us.



# WITHOUT YOU THERE IS NO US.

4800 Chavenelle Road | Dubuque, IA 52002  
1-800-AY-CARES | [aymcdonald.com](http://aymcdonald.com) | [aymcdonaldu.com](http://aymcdonaldu.com)  
(292-2737)

Follow us on social media

