



HYDROMATIC®

SP50/SP50AB

Submersible Sewage
Ejector Pump

Now Includes
SP50AB
Information

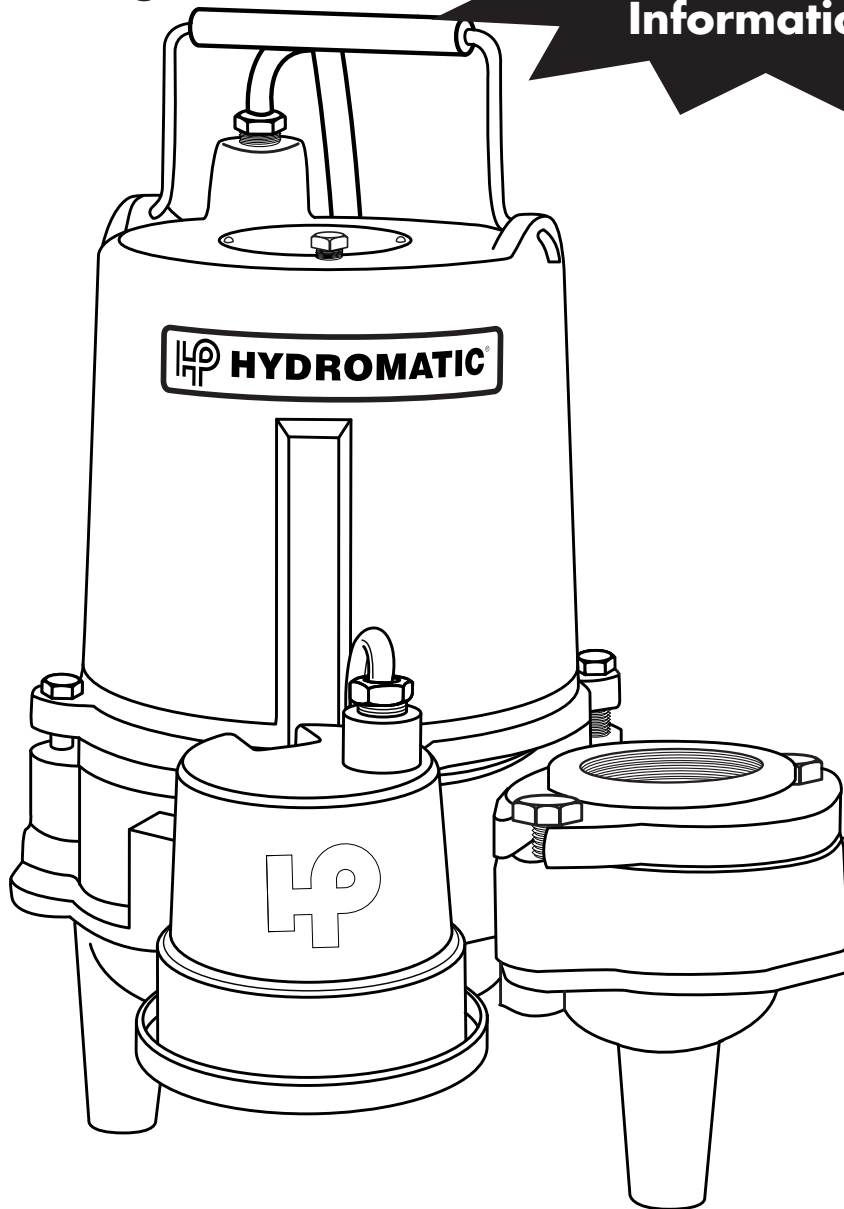

NOTE! To the installer: Please make sure you provide this manual to the owner of the pumping equipment or to the responsible party who maintains the system.



**Pentair
Water™**

General Information

Thank you for purchasing your Hydromatic® pump. To help ensure years of trouble-free operation, please read the following manual carefully.

Before Operation:

Read the following instructions carefully. Reasonable care and safe methods should be practiced. Check local codes and requirements before installation.

Attention:

This manual contains important information for the safe use of this product. Read this manual completely before using this product and refer to it often for continued safe product use. **DO NOT THROW AWAY OR LOSE THIS MANUAL.** Keep it in a safe place so that you may refer to it often.

WARNING: Before handling these pumps and controls, always disconnect the power first. Do not smoke or use sparkable electrical devices or flames in a septic (gaseous) or possible septic sump.

Pump Warning

To reduce risk of electrical shock:

1. Risk of Electrical Shock:

This pump has not been investigated for use in swimming pool areas.

2. Risk of Electrical Shock:

Connect only to a properly grounded receptacle.

Septic tank is to be vented in accordance with local plumbing codes.

Do not smoke or use sparkable electrical devices or flame in a septic (gaseous) or possible septic sump.

If a septic sump condition exists and if entry into sump is necessary, then (1) provide proper safety precautions per OSHA requirements and (2) do not enter sump until these precautions are strictly adhered to.

Do not install pump in location classified as hazardous per N.E.C., ANSI/NFPA 70 - 2001.

Failure to heed above cautions could result in injury or death.

Installation Instructions

These important instructions must be followed for satisfactory performance of your pump. Before installation, check your local electrical and plumbing codes.

1. Provide proper sump. Recommended minimum sump diameter is 18".
2. Make sure sump is free of string, cloth, nails, gravel, etc. before installing pump.
3. Do not set pump directly on the bottom of sump if it is not solid. Raise the pump by using bricks or concrete blocks underneath it.
4. Use steel or plastic pipe for all connecting lines between pump and sewer outlet.

NOTE: Some city regulations do not allow installing a pump with plastic pipe. Check local regulations.

5. In applications where the pump may sit idle for months at a time, it is recommended that the pump(s) be cycled every month to ensure the pumping system is working properly when needed.
6. Hydromatic check valve should be installed in discharge pipe.
7. An audible alarm system for high water conditions should be installed in every pump for greater protection, such as the Q Alert for indoor use, rated NEMA I. For additional control panels contact your Hydromatic distributor.
8. Connect to power source using 3-prong grounded AC receptacle. Do not remove ground pin from electrical plug. Do not use an extension cord.
9. Use pump partially or completely submerged for pumping waterlike liquids (temperature to 140° F). The SP50 will pump solid materials up to 1-1/2" (spherical) in diameter. This pump has not been investigated for use in swimming pool areas.
10. **Caution:** Do not pump flammable liquids, strong chemicals or salt water.

Pump Installation



Pump Servicing

Read the following instructions carefully before replacing any parts. Reasonable care and safe methods should be practiced. Check local codes and requirements before installation. Only competent electrician should make the installations.

Servicing should be performed only by knowledgeable pump service contractor or authorized service station.

Remove from power source.

WARNING: Shock hazard.

1. **Checking power cord.** To be sure wires are not burned off or broken in cord, use ohmmeter to check. Set ohmmeter scale pointer to R X 1 scale and attach one meter lead to white cord wire and one meter lead to black cord lead, then place screwdriver blade across blade terminals of plug. If cord is OK, meter needle will go to zero and stay there. If meter needle does not move, this will indicate an open wire and cord must be replaced.

2. **Checking motor operation.** When switch cap is off and switch is removed, connect two terminals that were connected to switch together and tape. Plug power cord in power receptacle to check motor operation. Motor should start and run smoothly. If motor does not start, pump must be dismantled and motor checked.

CAUTION: Be sure to unplug cord before continuing or reassembly if pump is functional.

3. **Checking motor stator.** If motor does not run when tested as described above, the stator must be removed from the housing and checked. Remove plug (12) from top of housing, and pour oil in container, preferably glass, so that oil can be observed.

If oil is clear it will indicate motor is not burned and there has been no water leaking into the motor. If oil is cloudy or black, it will indicate water in the motor or a burned stator.

After draining oil, remove bolts (10) and remove cord nut (25) from motor cord (21). Remove rubber seal ring from around cord. Turn cord and lift up until seal ring (26) is removed. Pry between ears of housing (24) to remove from base. Disconnect motor cord from stator and remove bolts (2) and plate. Lift stator from base. If stator is visibly burned, it must be replaced. If stator is not burned but the oil shows

signs of water, stator can be checked with the ohmmeter to see if it can be reused.

4. **Ground check.** Set ohmmeter scale pointer to R X 100K scale and check meter by putting both meter leads together and adjusting the needle knob until meter reads zero. If meter cannot be adjusted to zero it will indicate that batteries in meter must be replaced.

Check meter to zero and adjust if necessary before making any checks on motor.

Now connect one meter lead to one blade terminal of stator and touch other meter lead to motor stator shell. If needle reads below 5 (500,000 ohms) stator must be dried out before rechecking. To dry out, place motor in 220 degree oven for four hours. Recheck after motor cools. If motor is new or thoroughly dry, needle of ohmmeter will not move on the ground check: This indicates a reading of 50 megohms or higher. One megohm is one million ohms.

Performance Curve

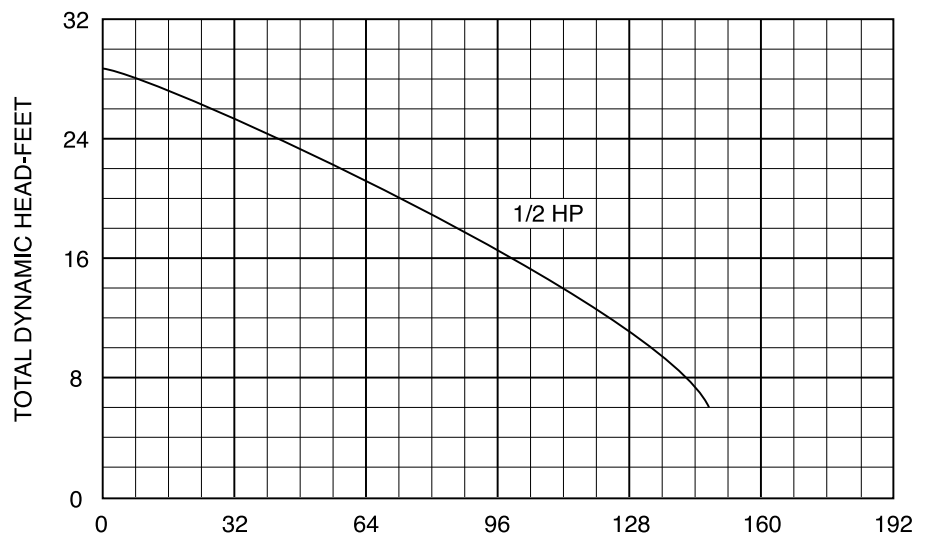

When making the ground check, if the needle goes to zero the motor in all probability has a wire touching the stator shell at some point and the stator will have to be replaced.

5. **Winding resistance test.** If motor shows a satisfactory ground check then the winding resistance must be checked. Use ohmmeter with scale pointer set on R X 1 scale. On this scale, meter reads directly on ohms. Always check the meter with leads together as described above, under ground check, before making a reading on the winding.

Connect one meter lead to the terminal with the brown wire connected underneath the terminal board. Connect the other lead to the terminal housing with the blue wire. Meter should read 1.2 to 1.4 ohms; this is the resistance of the main winding for a 115 volt stator. This reading for a 230 volt stator should be 4.8 to 5.9 ohms. Now connect one meter lead to the brown wire terminal and the other meter lead to the red wire beneath the terminal board. The meter should read 3.8 to 5.4 ohms for a 110 volt stator. For a 230 volt stator this reading should be 16 to 21 ohms. This is the resistance of the start winding. Now connect one meter lead to the red wire and one to the blue wire. The meter reading should be the sum of the other two readings or 5.0 to 6.8 ohms for a 115 volt stator or 20.8 to 26.9 ohms for a 230 volt stator. If the readings obtained do not agree with those given, the stator is defective and must be replaced.

6. **Replacing seal.** If water is found in motor, seal must be replaced. Remove bottom casting (5). Place screwdriver in shaft slot and tap impeller (6) lightly with hammer to unscrew. Use cloth on impeller to prevent cutting hand. Tap on end of shaft with a plastic or rubber hammer. This will push seal (8,9) from shaft. Clean case thoroughly; all sand and dirt must be removed. Remove stationary ceramic seat of seal from housing. Push new ceramic seat into housing. Use Parker O-ring lube on rubber ring. Replace rotor in housing. Use care in putting shaft through ceramic seat to be sure it is not chipped. Inspect seal after shaft is in place. If seal has been chipped it must be replaced. Do not replace rotating part of seal until the balance of the pump is assembled.

7. **Bearings.** When the pump rotor has been removed, check bearings before replacing. If bearings are rusted or rough when turned, they must be replaced. Pull bearings with a bearing puller. If puller cannot be replaced over lower bearing, remove the outer face by cracking in a vise. After outer face is cracked, it can be removed and the balls can be removed. This will allow inner face to be pulled.

When replacing bearings push only on inner face. If a press is not available, bearings can be tapped on, using a sleeve that bears only on the inner face.

Never pound on the outer face or bearing will be ruined.

8. **Reassembly of stator and housing.** Replace stator (20) with terminal block turned toward switch pocket as shown by drawing. Replace plate and bolts (2). Be sure ears on plate are in place inside of shell of stator.

Replace cord (21) with push on terminals in place on terminal block. Bend tabs of push on connectors down so that they cannot touch plate or housing. Place wire in straight up position so that housing (24) can be replaced over wire. Be sure bearing load springs are in place in housing before replacing housing. Hold springs in place in housing with O-ring lube, or other heavy grease. Be sure rubber ring (3) is in place on case when lowering housing into place. Tap down on top of housing with plastic or rubber hammer to seat over bearing. Replace screws (10) and tighten evenly from one side to the other until housing is firmly in place. At this point turn shaft to be sure rotor is free. If rotor binds, it indicates screws are not tightened evenly.

Push rubber seal ring (26) around cord and replace cord nut (25). Tighten cord nut tight. Nut must be tight enough so that cord cannot be pulled up. Put cord into switch cap and secure with rubber ring and nut. Replace switch as described earlier.

Now replace rotating part of seal (8). Use tapered installing sleeve furnished with seal to push over shaft threads. Screw impeller (6) onto shaft. Hold shaft with screwdriver in slot to tighten on impeller. Replace bottom casting (5).

Pump Servicing

Pump is now ready for check run before air testing and filling with oil. Plug cord (21) into power receptacle and push up on switch chamber diaphragm (23) to start motor. Motor should start and run smoothly. When pressure is released on diaphragm, motor should stop. Repeat operation 2 to 3 times to be sure operation is satisfactory and not binding.

9. **Air test.** To air test unit, put air fitting in plug opening (12) and charge motor housing with air to 7 psi. *Do not use higher pressure or seal will be blown open.* Charge switch cap with air through nylon vent tube as described earlier and place complete unit under water.

No air bubbles should show on this test. If leak shows, unit must be dismantled to correct leak.

10. **Oil fill.** After air test is satisfactory, remove from water and wipe or blow off any excess water.

Do not put oil in motor with any water present that could get into motor.

Fill to 1/8" over motor plate through opening. Use oil fill tube that will go into holes so that air can escape. Replace plug (12) and pump is ready for operation. Use only high grade transformer oil or special Hydromatic submersible oil in motor.

11. **Manual pumps.** All general instructions for automatic pumps apply to manual pumps except the level switch is not used and the power cord does not have a vent tube.

Manual models have the plug (12) in switch cap for installing a fitting to air test the pump for leaks. Replace all plugs with Permatex on threads. The switch housing seat is tapped and plugged with pipe plug.

Hydromatic pumps have a small air vent hole in the impeller cavity to let out trapped air. If this hole becomes plugged, pump may air lock. To break the air lock, use a small screwdriver to clear hole in the impeller cavity.

As a secondary precaution in installations of this type, 1/16" hole should be drilled in the discharge pipe below the check valve. The check valve should be 12 to 18 inches above pump discharge. Do not put check valve directly into pump discharge opening.

NOTE: In sumps where the pump is operating daily, air locking rarely occurs.

Performance Curve

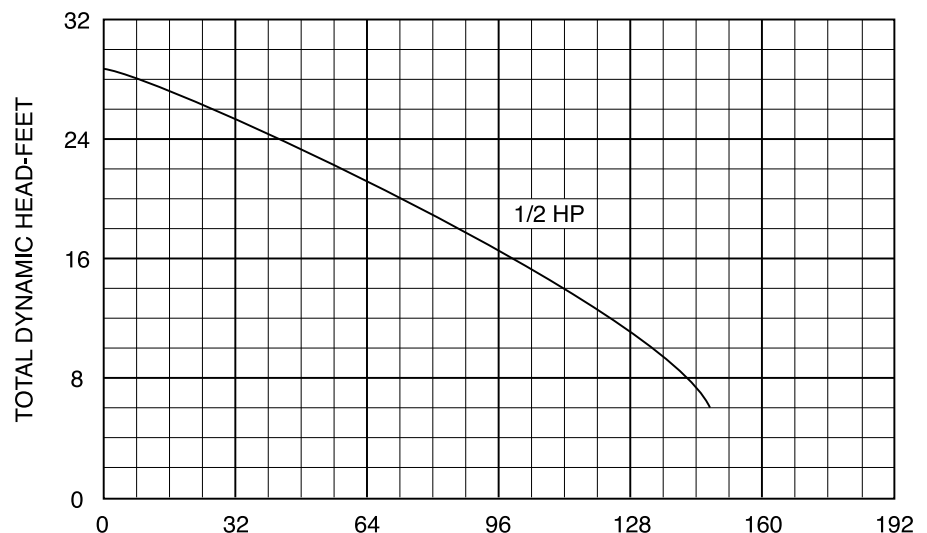

SP50 Parts List

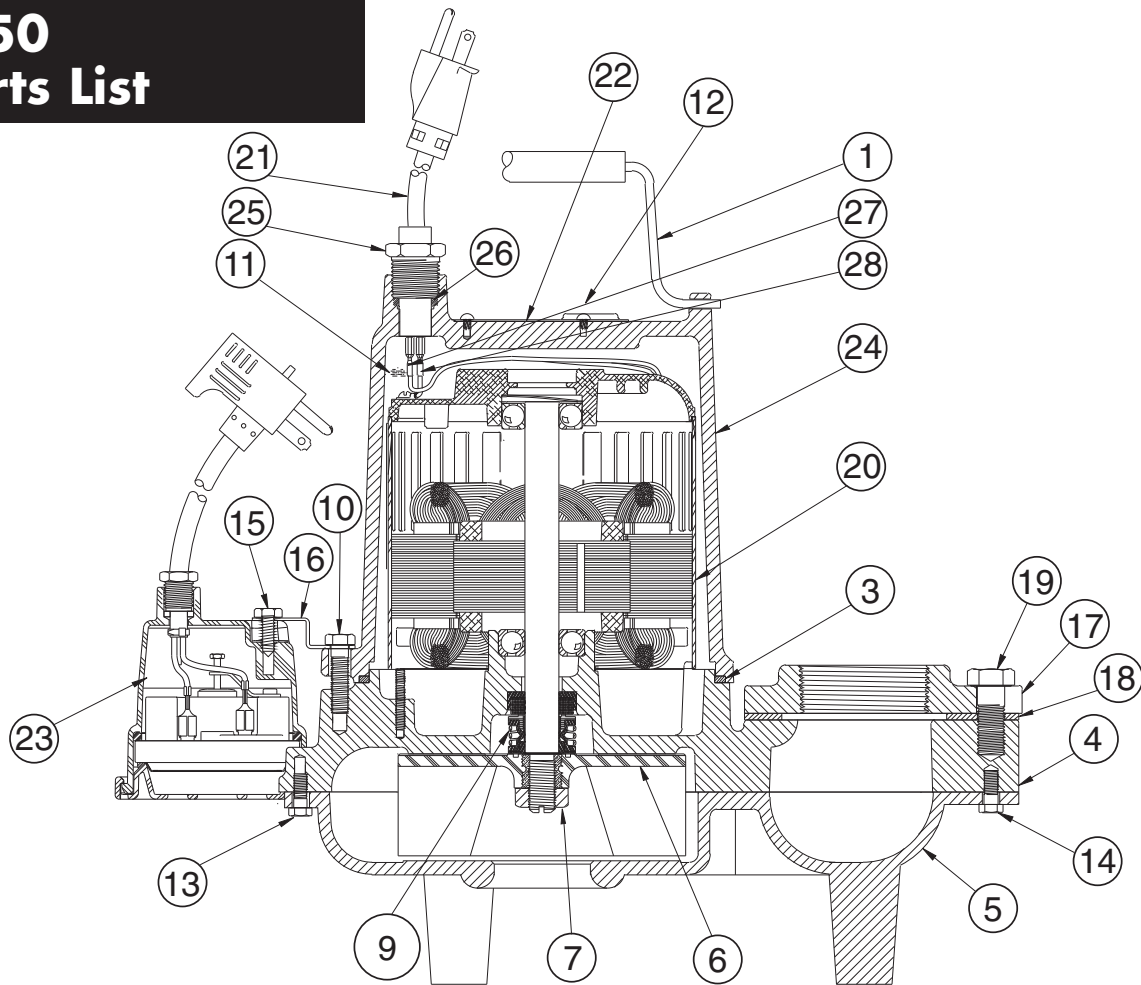

SP50A x SP50M x Single Phase

SP50A x SP50M x Three Phase

Ref. No.	Part No.	Description	Qty.	Ref. No.	Part No.	Description	Qty.
1	60-000-5	Handle – Pump	1	1	60-000-5	Handle – Pump	1
3	77-003-1	O-Ring Sq. cut	1	3	77-003-1	O-Ring Sq. cut	1
4	202-000-2	Volute	1	4	202-000-2	Volute	1
5	203-000-2	Bottom Plate	1	5	203-000-2	Bottom Plate	1
6	614-001-2	Impeller	1	6	614-001-2	Impeller	1
7	19109A070	Jam Nut	1	7	19109A070	Jam Nut	1
9	14525A010	Seal Assy.	1	9	14525A010	Seal Assy.	1
10	19100A012	Screw	4	10	19100A012	Screw	4
11	24709110000	Oil – Paraffinic	.54 gal.	11	24709110000	Oil – Paraffinic	1
12	14981-001-1	Plug – Pipe 1/4"	1	12	14981-001-1	Plug – Pipe 1/4"	1
13	19099A029	Screw – 1/4 - 20	2	13	19099A029	Screw – 1/4 - 20	2
14	—	—	—	14	—	—	—
15	30-021-1	Bolt	1	17	208-000-2	Flange – Discharge	1
16	5502-005-1	Bracket – Switch	1	18	324-001-1	Gasket – Discharge Flange	1
17	208-000-2	Flange – Discharge	1	19	19103A052	Bolt	2
18	324-001-1	Gasket – Discharge Flange	1	20	13594-000-1	Motor – 200 V. three phase	1
19	19103A052	Bolt	2	20	13595-000-1	Motor – 230 or 460 V. three phase	1
20	13349-000-1	Motor – 115 V. single phase	1	20	13596-000-1	Motor – 575 V. three phase	1
20	13592-000-1	Motor – 200 or 230 V. single phase	1	21	11644-089-5	Power Cord 20'	1
21	14623-010-1	Power Cord 10'	1	22	13425-070-1	Nameplate	1
21	14623-020-1	Power Cord 20'	1	24	56-023-2	Motor Housing	1
22	13425-069-1	Nameplate	1				
23	14974-008-5	Switch/Pressure Ass'y Pg	1				
24	56-036-2	Motor Housing	1				
25	75-005-1	Cord Nut	1				
26	139-014-1	Ring – Seal	1				
27	6000-053-1	Ground Wire	1				
28	6000-061-1	Black Wire	2				

NOTE: Use Loctite on Impeller threads

SP50AB1 Parts List

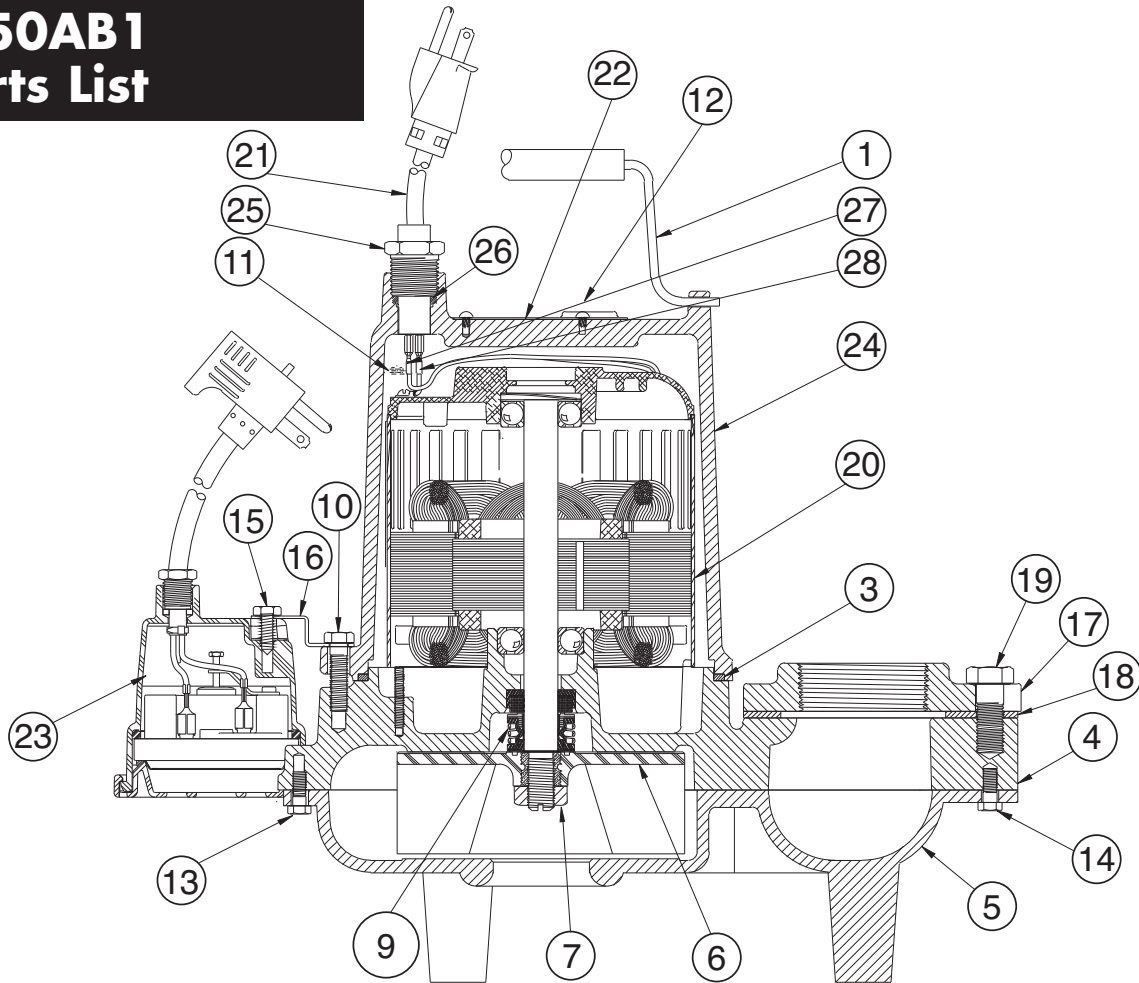

SP50AB1

Ref. No.	Part No.	Description	Qty.
1	60-000-5	Handle – Pump	1
3	77-003-1	O-Ring Sq. cut	1
4	202-010-2	Volute	1
5	203-010-2	Bottom Plate	1
6	614-010-2	Impeller	1
7	19109A070	Jam Nut	1
9	14525A010	Seal Assy.	1
10	19100A012	Screw	4
11	—	Oil – Paraffinic	1
12	05022A088	Plug – Pipe 1/4"	1
13	19099A029	Screw – 1/4 - 20	2
14	—	—	—
15	30-021-1	Screw	1
16	5502-005-1	Bracket – Switch	1
17	208-010-2	Flange – Discharge	1
18	324-001-1	Gasket – Discharge Flange	1
19	19103A052	Bolt	2
20	13349-000-1	Motor – 115 V. single phase	1
21	14623-020-1	Power Cord 20'	1
22	13425-069-1	Nameplate	1
23	14974-309-5	Switch/Pressure Ass'y Pg	1
24	56-013-2	Motor Housing	1
25	75-007-1	Cord Nut	1
26	139-014-1	Ring – Seal	1

NOTE: Use Loctite on Impeller threads

WARRANTY

Hydromatic® warrants to the original purchaser of each Hydromatic product(s) that any part thereof that proves to be defective in material or workmanship within one year from date of installation or 18 months from manufacture date, whichever comes first, will be replaced at no charge with a new or remanufactured part, F.O.B. factory. Purchaser shall assume all responsibility and expense from removal, reinstallation and freight. Any item(s) designated as manufactured by others shall be covered only by the express warranty of the manufacturer thereof. This warranty does not apply to damage resulting from accident, alteration, design, misuse or abuse. The pump must be installed, operated and maintained in accordance with the published instructions of the appropriate Installation & Service Manual.

All dual seal non-clogs and 3–5 HP grinders must have seal failure and heat sensors attached and functional for Warranty to be in effect. If a seal failure should occur, Hydromatic will cover only the lower seal and labor thereof. Labor is based on Authorized Service Center contract allowance. If the heat sensor is not attached and functional, Warranty is void. If the seal failure sensor is not attached and functional, Warranty is void.

If the material furnished to the Buyer shall fail to conform to this contract or to any of the terms of this written warranty, Hydromatic shall replace such nonconforming material at the original point of delivery and shall furnish instruction for its disposition. Any transportation charges involved in such disposition shall be for the Buyer's account. The Buyer's exclusive and sole remedy on account or in respect of the furnishing of material that does not conform to this contract or to this written warranty, shall be to secure replacement thereof as aforesaid. Hydromatic shall not in any event be liable for the cost of any labor expended on any such material or for any incidental or consequential damages to anyone by reason of the fact that such material does not conform to this contract or to this written warranty.

ALL IMPLIED WARRANTIES, INCLUDING THE IMPLIED WARRANTY OF MERCHANTABILITY AND THE IMPLIED WARRANTY OF FITNESS FOR A PARTICULAR PURPOSE, ARE DISCLAIMED TO THE SAME EXTENT AS THE EXPRESS WARRANTY CONTAINED HEREIN. Some states do not allow limitations on how long an implied warranty lasts, so the above limitation may not apply to you.

MANUFACTURER EXPRESSLY DISCLAIMS AND EXCLUDES ANY LIABILITY FOR CONSEQUENTIAL OR INCIDENTAL DAMAGES FOR BREACH OF ANY EXPRESS OR IMPLIED WARRANTY ARISING IN CONNECTION WITH THIS PRODUCT, INCLUDING WITHOUT LIMITATION, WHETHER IN TORT, NEGLIGENCE, STRICT LIABILITY CONTRACT OR OTHERWISE. Some states do not allow the exclusion or limitation of incidental or consequential damages, so the above limitation or exclusion may not apply to you. This warranty gives you specific legal rights, and you may also have other rights which vary from state to state.



HYDROMATIC®

Pentair Water

USA

740 East 9th Street, Ashland, Ohio 44805
Tel: 419-289-3042 Fax: 419-281-4087



www.hydromatic.com

– Your Authorized Local Distributor –

CANADA

269 Trillium Drive, Kitchener, Ontario, Canada N2G 4W5
Tel: 519-896-2163 Fax: 519-896-6337