

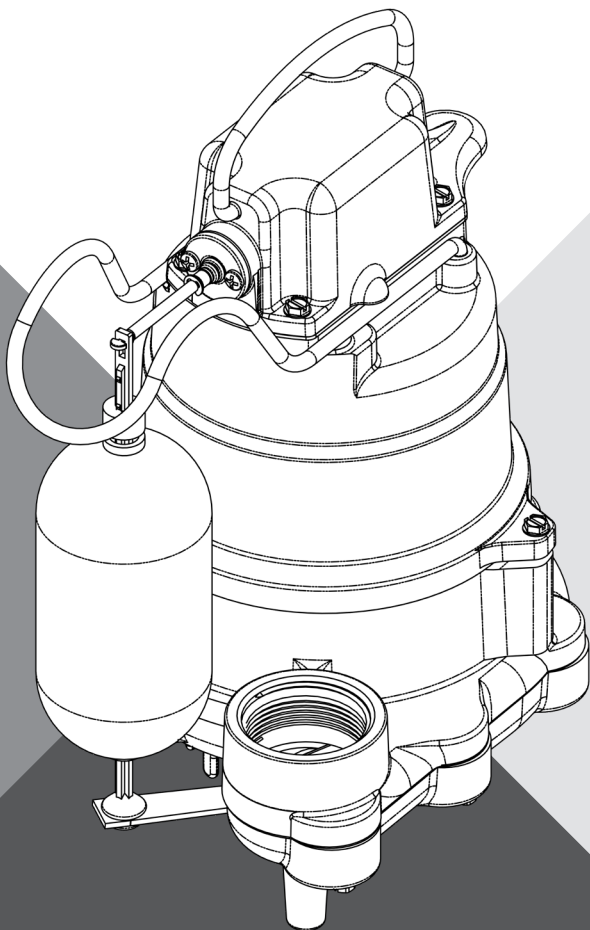

SUBMERSIBLE SUMP/EFFLUENT PUMPS SERIES MC10



INSTALLATION AND OPERATION MANUAL

pentair.com

TABLE OF CONTENTS / SAFETY

INTRODUCTION

Safety Instructions.....	3
Installation.....	4
Repair Parts Index	6
Troubleshooting	7
Warranty.....	8

SAFETY INSTRUCTIONS

SAFETY SYMBOLS

 This is the safety alert symbol. When you see this symbol on your pump or in this manual, look for one of the following signal words and be alert to the potential for personal injury:

 **DANGER** warns about hazards that will cause serious personal injury, death or major property damage if ignored.

 **WARNING** warns about hazards that can cause serious personal injury, death or major property damage if ignored.

 **CAUTION** warns about hazards that will or can cause minor personal injury or property damage if ignored.

The word **NOTICE** indicates special instructions that are important but not related to hazards.

GENERAL SAFETY

Electrically powered sump pumps normally give many years of trouble-free service when correctly installed, maintained, and used. However, unusual circumstances (interruption of power to the pump, dirt/debris in the sump, flooding that exceeds the pump's capacity, electrical or mechanical failure in the pump, etc.) may prevent your pump from functioning normally. To prevent possible water damage due to flooding, consult your dealer about installing a secondary sump pump, a DC backup sump pump, and/or a high water alarm. See the "Troubleshooting Chart" in this manual for information about common sump pump problems and remedies. For more information, see your dealer.

1. Know the pump application, limitations, and potential hazards.
2. Disconnect the power before servicing.
3. Release all pressure within the system before servicing any component.
4. Drain all water from the system before servicing.
5. Secure the discharge line before starting the pump. An unsecured discharge line will whip, possibly causing personal injury and/or property damage.
6. Check the hoses for a weak or worn condition before each use. Make certain all connections are secure.
7. Periodically inspect the sump, pump and system components. Keep free of debris and foreign objects. Perform routine maintenance as required.
8. Provide a means of pressure relief for pumps whose discharge line can be shut-off or obstructed.
9. Personal Safety:
 - ◆ Wear safety glasses at all times when working with pumps.
 - ◆ Keep the work area clean, uncluttered and properly lighted – replace all unused tools and equipment.
 - ◆ Keep visitors at a safe distance from work area.
 - ◆ Make the workshop child-proof – with padlocks, master switches, and by removing starter keys.

10. When wiring an electrically driven pump, follow all electrical and safety codes that apply.

11. This equipment is only for use on 115 volt (single phase) and is equipped with an approved 3-conductor cord and 3-prong, grounding-type plug.

 **WARNING** Electrical shock hazard. Can burn or kill. To reduce risk of electric shock, pull plug before servicing. Pump is supplied with a grounding conductor and grounding-type attachment plug. Be sure it is connected only to a properly grounded grounding-type receptacle.

Where a 2-prong wall receptacle is encountered, it must be replaced with a properly grounded 3-prong receptacle installed in accordance with codes and ordinances that apply.

This pump has not been investigated for use in swimming pool areas.

12. All wiring should be performed by a qualified electrician.
13. Make certain the power source conforms to the requirements of your equipment.
14. Protect the electrical cord from sharp objects, hot surfaces, oil, and chemicals. Avoid kinking the cord. Replace or repair damaged or worn cords immediately.
15. Do not touch an operating motor. Motors can operate at high temperatures.

Do not handle the pump or pump motor with wet hands or when standing on wet or damp surface, or in water.

 **WARNING** Electrical shock hazard. Can burn or kill. If your basement has water or moisture on floor, do not walk on wet area until all power has been turned off. If shut-off box is in basement, call electric company or hydro authority to shut-off service to house, or call your local fire department for instructions. Remove pump and repair or replace. Failure to follow this warning can result in fatal electrical shock.

16. Pump water only with this pump. Do not use with salt water or brine.
17. Do not install the pump in any location classified as hazardous by the National Electric Code, ANSI/NFPA 70-2011 or the Canadian Electrical Code.

CALIFORNIA PROPOSITION 65 WARNING

 **WARNING** This product and related accessories contain chemicals known to the State of California to cause cancer, birth defects or other reproductive harm.

INSTALLATION

These Submersible Sump Pumps are designed for home sumps. The unit is equipped with a 3-prong grounding-type power cord. The shaded-pole motor is oil filled and sealed for cooler running. Upper sleeve/lower ballbearing on the motor shaft never need lubrication. Automatic reset thermal protection.

SPECIFICATIONS

Power supply required.....115V, 60 HZ.
 Liquid Temp. Range.....32°F to 130°F (0°-54°C)
 Individual Branch Circuit Required.....15-20 Amps
 Discharge.....1-1/2" NPT

PERFORMANCE

INSTALLATION

1. Install the pump in a sump pit with a minimum diameter of 11" (279mm). The sump depth should be 20" minimum (381mm). Construct the sump pit of tile, concrete, steel or plastic. Check the local codes for approved materials.
2. Adjust the float stop on the rod to adjust the pump "ON" point. "OFF" point is factory preset.
3. The pump should not be installed on clay, earth or sand surfaces. Clean the sump pit of small stones and gravel which could clog the pump. Keep the pump inlet screen clear.
4. Install the pump in the pit so that the switch operating mechanism has maximum possible clearance.
5. Install the discharge plumbing. When using rigid pipe, use plastic pipe. Wrap the threads with PTFE pipe thread sealant tape. Screw the pipe into the pump hand tight plus 1 to 1-1/2 turns.

NOTICE: Do not use ordinary pipe joint compound on plastic pipe. Pipe joint compound can attack plastics and damage the pump.

CAUTION Risk of flooding. If a flexible discharge hose is used, make sure the pump is secure in the sump to prevent movement. Failure to secure the pump may allow pump movement, switch interference and prevent the pump from starting or stopping.

6. To reduce motor noise and vibrations, a short length of rubber hose (e.g. radiator hose) can be connected into the discharge line near the pump using suitable clamps.
7. Install an in-line check valve to prevent backward flow through the pump when the pump shuts off.
8. Power Supply: The pump is designed for 115 V., 60 Hz., operation and requires a minimum 15 amp individual branch circuit. The pump is supplied with a 3-wire cord set with grounding-type plug. Do not modify cord or plug. Be sure it is connected only to a properly grounded grounding-type receptacle.

WARNING Hazardous voltage. Can shock, burn or kill.

The pump should always be electrically grounded to a suitable electrical ground such as a grounded water pipe or a properly grounded metallic raceway, or ground wire system. Do not modify the cord or plug or cut off the round ground pin.

9. If the pump discharge line is exposed to an outside sub-freezing atmosphere, the portion of the line exposed must be installed so any water remaining in the pipe will drain to the outfall by gravity. Failure to do this can cause the water trapped in the discharge to freeze which could result in damage to the pump.
10. After the piping and check valve have been installed, the unit is ready for operation.
11. Check the operation by filling the sump with water and observing pump operation through one complete cycle.

WARNING Risk of Flooding. Failure to make this operational check may lead to improper operation, premature failure, and flooding.

CAPACITY GPM (LPM) AT TOTAL FEET (M)						
MODEL	5 (1.5m)	10 (3m)	15 (4.6m)	20 (6.1m)	25 (7.6m)	
MCI033	48(182)	40(151)	28(106)	15(57)	-	24ft(7.3m)
MCI050	62(235)	53(201)	47(178)	38(144)	28(106)	32ft(9.8m)

INSTALLATION

OPERATION / MAINTENANCE

⚠ WARNING Risk of electrical shock. Can burn or cause death. Do not handle a pump or pump motor with wet hands or when standing on a wet or damp surface, or in water.

Before attempting to check why unit has stopped operating, disconnect power from unit.

⚠ WARNING **Risk of fire and explosion.** Can cause severe injury, property damage or death. Do not use in explosive atmospheres. Pump water only with this pump.

1. The shaft seal depends on water for lubrication and cooling. Do not operate the pump unless it is submerged in water as the seal may be damaged if allowed to run dry.
2. The motor is equipped with an automatic reset thermal protector. If the temperature in the motor should rise unduly, the switch will cut off all power before damage can be done to the motor. When the motor has cooled sufficiently, the switch will reset automatically and restart the motor. If the protector trips repeatedly, the pump should be removed and checked as to cause of difficulty. Low voltage, long extension cords, clogged impeller, very low head or lift, etc., could cause cycling.
3. The pump will not remove all water. If a pump is operating and suddenly no water comes out of the discharge hose, shut the unit off immediately. The water level is probably very low and the unit has broken prime.

AIRLOCKS

When a pump airlocks, it runs but does not move any water. An airlock will cause the pump to overheat and fail. These pumps have a built in anti-airlock hole. See the exploded view on the repair parts page for the location of the hole. Leakage from the anti-airlock hole is normal

If you suspect an airlock, unplug the pump, clean out the anti-airlock hole with a paper clip or a piece of wire, and restart the pump

MOTOR AND CORD SPECIFICATIONS

MODEL	CORD LENGTH	LOWER CASING VOLUTE MATERIAL	VOLTS	PHASE	AMPS	INDIVIDUAL BRANCH CIRCUIT REQUIRED (AMPS)	DISCHARGE	SWITCH
MCI033	10' (3.1 m)	Engineered Polymer	115	1	9.8	15	1-1/2" NPT	Vertical
MCI03320	20' (6.1 m)	Engineered Polymer	115	1	9.8	15	1-1/2" NPT	Vertical
MCI033CI	10' (3.1 m)	Cast Iron	115	1	9.8	15	1-1/2" NPT	Vertical
MCI050	10' (3.1 m)	Engineered Polymer	115	1	12.0	20	1-1/2" NPT	Vertical
MCI05020	20' (6.1 m)	Engineered Polymer	115	1	12.0	20	1-1/2" NPT	Vertical
MCI050CI	10' (3.1 m)	Cast Iron	115	1	12.0	20	1-1/2" NPT	Vertical

*Rest of pump is Cast Iron

REPAIR PARTS INDEX

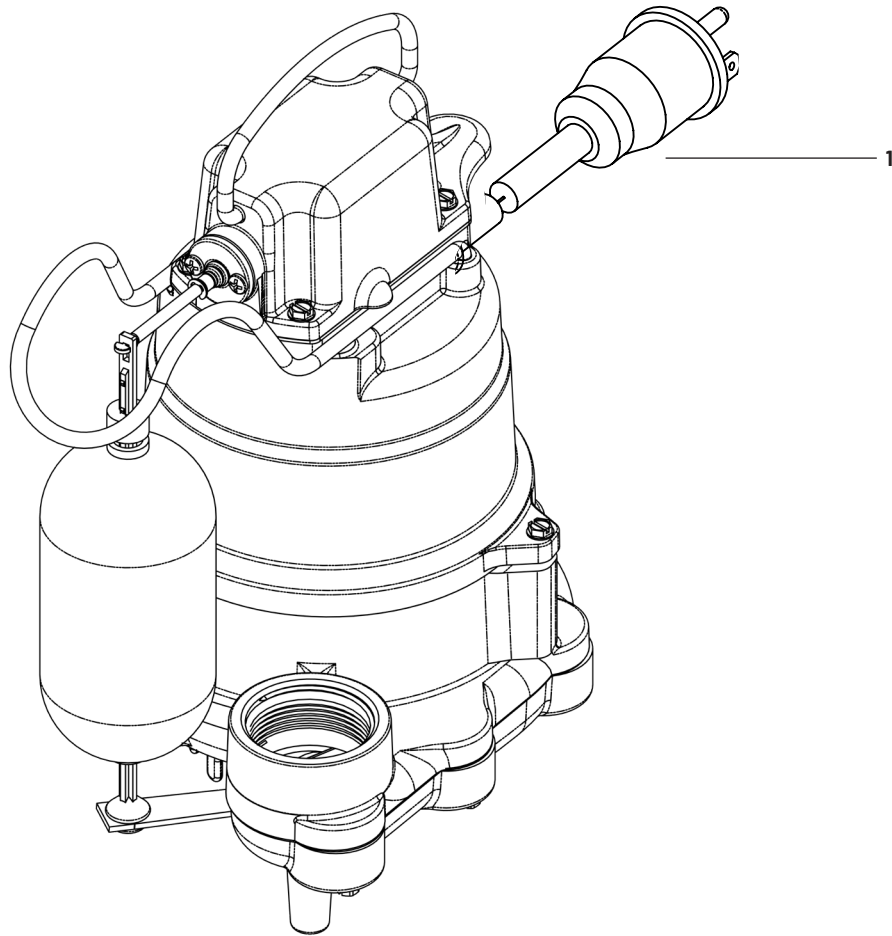

REF. NO.	DESCRIPTION	QTY	MCI033	MCI050
1	Power Cord 10'	1	PW117-237-TSU	PW117-237-TSU
	Power Cord 20'	1	PW117-122-TSU	PW117-122-TSU
	Power Cord 30'	1	PW117-293-TSU	PW117-293-TSU

TROUBLESHOOTING

SYMPTOM	PROBABLE CAUSE(S)	ACTION
PUMP WON'T RUN OR START.	◆ Blown fuse.	◆ If blown, replace with a fuse of proper size.
	◆ Low Line Voltage.	◆ If the voltage is under the recommended minimum, check the size of the wiring from the main switch on the property. If OK, contact power company or hydro authority.
	◆ Defective motor.	◆ Replace the pump.
	◆ Defective float switch.	◆ Replace the float switch.
	◆ Impeller.	◆ If the impeller won't turn, remove the lower pump body and locate the source of the binding.
PUMP STARTS AND STOPS TOO OFTEN.	◆ Float is obstructed.	◆ Remove the obstruction.
	◆ Backflow of water from piping.	◆ Install or replace the check valve.
	◆ Faulty float switch.	◆ Replace the float switch.
PUMP WON'T SHUT OFF.	◆ Defective float switch.	◆ Replace the float switch.
	◆ Restricted discharge (obstacle in piping).	◆ Remove the pump and clean the pump and piping.
	◆ Float obstructed.	◆ Remove the obstruction.
PUMP OPERATES BUT DELIVERS LITTLE OR NO WATER.	◆ Low line voltage.	◆ If the voltage is under the recommended minimum, check the size of the wiring from the main switch on the property. If OK, contact power company or hydro authority.
	◆ Something is caught in impeller.	◆ Clean out the impeller.
	◆ Anti-airlock hole is plugged.	◆ Turn off the pump, clean out the anti-airlock hole, and restart pump.

Limited Warranty

Myers warrants to the original consumer purchaser ("Purchaser" or "You") of the products listed below, that they will be free from defects in material and workmanship for the Warranty Period shown below.

Product	Warranty Period whichever occurs first:
Jet pumps, small centrifugal pumps, submersible pumps and related accessories	12 months from date of original installation, or 18 months from date of manufacture
Fibrewound Tanks	5 years from date of original installation
Steel Pressure Tanks	5 years from date of original installation
Sump/Sewage/Effluent/Utility/Battery Backup Products	36 months from date of manufacture
Wastewater Solids Handling Pumps	12 months from date of shipment from factory or 18 months from date of manufacture

Our warranty applies **only** where such products are used in compliance with the requirements of the applicable product catalog and/or manuals. For additional information, please refer to the applicable standard limited warranty featured in the product manual.

Our warranty will **not** apply to any product that, in our sole judgment, has been subject to negligence, misapplication, improper installation, or improper maintenance. Without limiting the foregoing, operating a three phase motor with single phase power through a phase converter will void the warranty. Note also that three phase motors must be protected by three-leg, ambient compensated, extra-quick trip overload relays of the recommended size or the warranty is void.

Your only remedy, and MYERS's only duty, is that MYERS repair or replace defective products (at MYERS's choice). You must pay all labor and shipping charges associated with this warranty and must request warranty service through the installing dealer as soon as a problem is discovered. No request for service will be accepted if received after the Warranty Period has expired. This warranty is not transferable.

MYERS SHALL NOT BE LIABLE FOR ANY CONSEQUENTIAL, INCIDENTAL, OR CONTINGENT DAMAGES WHATSOEVER.

THE FOREGOING LIMITED WARRANTIES ARE EXCLUSIVE AND IN LIEU OF ALL OTHER EXPRESS AND IMPLIED WARRANTIES, INCLUDING BUT NOT LIMITED TO IMPLIED WARRANTIES OF MERCHANTABILITY AND FITNESS FOR A PARTICULAR PURPOSE. THE FOREGOING LIMITED WARRANTIES SHALL NOT EXTEND BEYOND THE DURATION PROVIDED HEREIN.

Some states do not allow the exclusion or limitation of incidental or consequential damages or limitations on the duration of an implied warranty, so the above limitations or exclusions may not apply to You. This warranty gives You specific legal rights and You may also have other rights which vary from state to state.

This Limited Warranty is effective January 1, 2021 and replaces all undated warranties and warranties dated before January 1, 2021.

PENTAIR MYERS
293 Wright Street, Delavan, WI 53115
Phone: 888-987-8677 • Fax: 800-426-9446 • www.femyers.com
In Canada: 490 Pinebush Road, Unit 4, Cambridge, Ontario N1T 0A5
Phone: 800-363-7867 • Fax: 888-606-5484



US
293 WRIGHT ST
DELAVAN, WI 53115
PH: 866-973-6835
ORDERS FAX: 800-321-8793

CANADA
490 Pinebush Road, Unit 4
Cambridge, Ontario, Canada N1T
0A5
PH: 800-363-7867

pentair.com