

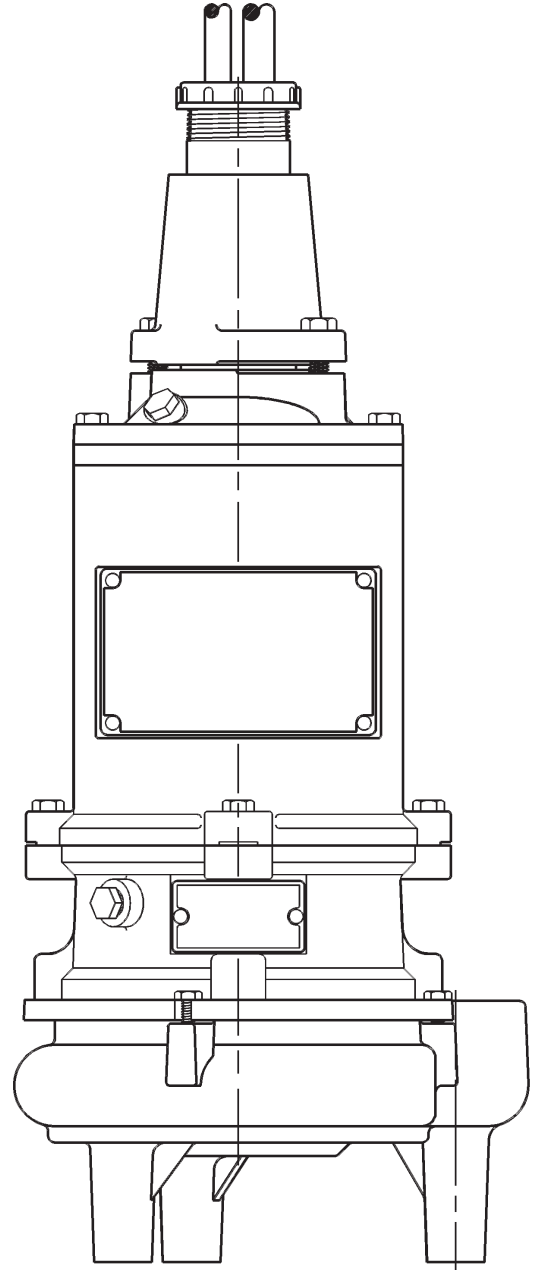

**MYERS®**

The submersible SX Series pumps are CSA approved for use in Class I, Division 1, Group D hazardous locations in wastewater and storm water applications. The SX Series pumps are not intended for applications requiring the pumping of flammable liquids. A triplex system is recommend to reduce the possibility of concentrations of flammable/hazardous liquids entering the main lift station.



# SX SERIES

(Class I, Division 1, Group D)

## INSTALLATION AND SERVICE MANUAL



NOTE! To the installer: Please make sure you provide this manual to the owner of the equipment or to the responsible party who maintains the system.

**WARNING! IMPORTANT SAFETY INSTRUCTIONS! READ CAREFULLY BEFORE INSTALLATION.** This manual contains important information for the safe use of this product. Read this manual completely before using this product and refer to it often for continued safe product use. **DO NOT THROW AWAY OR LOSE THIS MANUAL.** Keep it in a safe place so that you may refer to it often.

**DANGER: Risk of Electrical Shock or Electrocution.** May result in serious injury or death or fire hazard. Installer must disconnect all electrical sources prior to installation, handling or servicing. Only qualified personnel may install this system. NFPA 70/National Electric Code (NEC) or local codes must be followed. System must be properly grounded according to NEC. Do not lift pump by power cord.

**DANGER: Biohazard Risk.** Once wastewater source has been connected to system, biohazard risk exists. Installer(s) and/or service personnel must use proper personal protective equipment and follow handling procedures per OSHA 29 CFR 1910.1030 when handling equipment after wastewater source has been connected to system.

**DANGER: Risk of Asphyxiation.** Installer(s) and/or service personnel must use proper personal protective equipment and follow OSHA 29 CFR 1910.146 or OSHA 29 CFR 1926. Pump may be installed in a location classified as a confined space.

**DANGER: Risk of Fire or Explosion.** Do not smoke or use open flames in or around this system. This system is not intended for use in hazardous locations per NFPA 70 National Electric Code. Do not pump flammable liquids. Consult factory for optional equipment rated for hazardous location use.

**CALIFORNIA PROPOSITION 65 WARNING:**

**▲ WARNING** This product and related accessories contain chemicals known to the State of California to cause cancer, birth defects or other reproductive harm.

**GENERAL**

1. Most accidents can be avoided by using **COMMON SENSE.**
2. Read the operation and maintenance instructions manual supplied with the pump.
3. Do not wear loose clothing that can become entangled in the impeller or other moving parts.

**ELECTRICAL**

4. To reduce risk of electrical shock, disconnect the pump from the power source before handling or servicing.
5. Any wiring to be done on pumps should be done by a qualified electrician.
6. Never operate a pump with a power cord that has frayed or brittle insulation.
7. Never let cords or plugs lie in water.
8. Never handle connected power cords with wet hands.

**PUMPS**

9. Pump builds up heat and pressure during operation; allow time for pump to cool before handling or servicing.

10. Only qualified personnel should install, operate or repair pump.
11. Keep clear of suction and discharge openings. **DO NOT** insert fingers in pump with power connected.
12. Do not pump hazardous material not recommended for pump (flammable, caustic, etc.).
13. Make sure lifting handles are securely fastened each time before lifting.
14. Do not exceed manufacturer's recommendation for maximum performance, as this could cause the motor to overheat.
15. Secure the pump in its operating position so it cannot tip over, fall or slide.
16. Keep hands and feet away from impeller when power is connected.
17. Submersible pumps are not approved for use in swimming pools, recreational water installations, decorative fountains or any installation where human contact with the pumped fluid is common.
18. Do not operate pump without safety devices in place.
19. For hazardous locations, use pumps that are listed and classified for such locations.

**IMPORTANT! Myers is not responsible for losses, injury or death resulting from a failure to observe these safety precautions, misuse or abuse of pumps or equipment.**

**Motor HP & Voltages:** The SX Series pumps are offered in single and three phase. Voltages will vary according to the application, for details consult factory.

**Electrical Controls:** All of these pump models must be used with a control panel. Myers built control panels are designed to supply the correct electrical controls, motor starting equipment and include the circuitry for moisture and heat sensors. It is recommended that a Myers built control panel be used so that all warranties apply.

**General Construction:** The SX Series motor construction is designed to meet CSA requirements for Class I, Group D sewage applications. The motor chamber and seal chamber are filled with a high dielectric type oil for improved lubrication and heat transfer of the bearings and motor. An air space above the oil level in both the seal and motor chambers is provided to allow for the expansion of the oil when at operating temperature. The power and control lines are sealed and strain relieved on the outside entrance with a standard cord grip, and internally through the use of a dielectric potting resin surrounding the electrical wires.

**General Installation:** Various configurations and methods of plumbing this series may be used.

**Note:** If the SX Series hazardous location pumps are used in conjunction with a rail lift-out system, it must be a listed or recognized nonsparking system for hazardous locations.

These pumps are to be used for handling septic tank effluent, sewage, and storm water only. **Do not** use in other hazardous locations. These motors must be repaired and serviced only at a Myers authorized service center or at the Myers factory. Any unauthorized field repair voids warranty and the hazardous location rating.

**CAUTION: Sewage water gives off methane and hydrogen sulfide gases, which are poisonous. It is for this reason that Myers recommends using the rail lift-out system so that no service is required inside the basin.**

**Motor:** Each motor is provided with heat sensor thermostats attached directly to the motor windings. The thermostats open if the motor windings see excessive heat and, in turn, open the motor contactor in the control panel, breaking the power to the pump. When the motor is stopped due to an overheat condition, it will not start until the motor has cooled and the heat sensor reset button is manually pushed on the front of the Myers control panel. This circuitry is provided in the Myers control panel designs.

The SX Series pumps are equipped with internal thermostats.

**Note:** Failure to use proper circuitry and to connect the motor overheat protection in the control panel would negate all warranties and CSA Listings.

**Motor Seal Failure Warning:** The seal chamber is oil filled and provided with moisture sensing probes to detect water leakage through the lower shaft seal. The probes can also detect moisture present in the upper motor housing.

The presence of water energizes a red seal leak warning light at the control panel. This is a warning light only, and does not stop the motor. It indicates a leak has occurred and the pump must be repaired. Normally, this indicates the outboard seal has leaked. Allowing the unit to operate after the warning could cause upper seal leakage along with motor failure.

On the Myers control panels the seal leak test switch tests the seal leak circuit continuity. When pushed the seal leak test bulb should light. If the test bulb does not light it means either the wiring circuitry to the seal leak probes have been broken or the bulb has burned out.

**Note:** Myers built control panels supply the correct circuitry for moisture and heat sensor connections. Failure to install the correct circuitry with proper connection would negate warranty and CSA Listing.

**Motor Power Cord, Control Cord and Cord Cap Assembly:** Each motor power cord has 4 conductors – white, black, red and green. For a single phase motor the black is connected to the common lead, the white is connected to the main lead, while the red is connected to the start circuitry, and the green is attached to a good ground. The rotation of a single phase pump is set properly at the factory.

For three phase motor, the black, white, and red conductors are power leads and the green is ground.

**Note:** Rotation should be clockwise when observed from the top of the pump. This can be checked by noting which direction the pump torques upon initial starting. A properly

rotating pump will torque counterclockwise upon start.

### **ALWAYS CHECK THREE PHASE PUMPS FOR PROPER ROTATION BEFORE INSTALLING PUMPS.**

The control cable has 5 conductors – black, white, red, orange and green. White and black connect to the heat sensor terminals in the control panels; red and orange connect to the seal failure terminals in the control panel; and the green connects to the ground in the control panel.

#### **The control and power cables cannot be spliced!**

**Note:** Each cable has a green ground wire and must be properly grounded per the National Electric Code and local codes.

**Electrical Motor Controls:** All electrical controls and motor starting equipment should be specified from factory. Consult factory for any acceptable alternatives. For hazardous locations the controls and control panel must be installed outside the hazardous area. Only approved controls that are intrinsically safe may be used with these pumps.

**Junction Box:** If a junction box is used in a hazardous location, it must be an approved type with approved cord connectors. Wires from the junction box must pass through an approved seal connector for hazardous locations.

**Level Sensing Controls:** Intrinsically safe-type float controls are recommended for all applications and required for hazardous locations. An intrinsically safe control panel relay will limit the current and voltage to the level controls. A Myers control panel can be supplied with this type circuitry. The float level controls maintain the basin sewage water level by controlling pump turn-on and turn-off levels.

1. The lower turn-off control should be set so that the pump stops with the water covering the entire motor housing. Consult the factory for any settings below this point.
2. The upper turn-on control should be set above the lower turn-off control. The exact height between the two controls is determined by the number of pump starts desired and the depth of the basin. A maximum of 10 starts per hour should not be exceeded.
3. The override control is set at a specified height above the upper turn-on control.
4. The alarm control is set about 6" to 12" above the override control.
5. No control should be set above the inlet invert.

**Electrical Connections:** Complete wiring diagrams are included for use in making the installation. All wires should be checked for shorts to ground with an ohmmeter or megger after the connections are made. This is important, as one grounded wire can cause failure of the pump, control panel or personal injury.

## TROUBLESHOOTING

CONDITION	PROBABLE CAUSE
Red light comes on at control box.	This indicates some water has leaked past the lower seal and has entered the seal chamber and made contact with the electrode probe. Pump must be removed for replacement of lower seal. This preventive repair will save an expensive motor.
Overload trips at control box and alarm buzzer or flashing red light comes on due to high water level in basin.	<ol style="list-style-type: none"><li>1. Push in on red reset button to reset overload. If overload trips again after short run, pump has some damage and must be removed from basin for checking.</li><li>2. Trouble may be from clogged impeller causing motor to overload or could be from failed motor.</li><li>3. Trouble may be from faulty component in control box. Always check control box before removing pump.</li></ol>
Yellow run light stays on continuously.	<ol style="list-style-type: none"><li>1. Indicates H-O-A switch may be in the Hand position.</li><li>2. Level control switch may have failed causing pump to continue to operate when water is below lower control.</li><li>3. Impeller may be partially clogged causing pump to operate at very reduced capacity.</li><li>4. Gate valve or check valve may be clogged causing low pump flow.</li><li>5. Pump may be air locked.</li></ol>
Circuit breaker trips.	<ol style="list-style-type: none"><li>1. Reset breaker by pushing completely down on handle then back to On position. If breaker trips again in few seconds it indicates excessive load probably caused by a short in the motor or control box. Check out instructions given with control box before pulling pump.</li><li>2. If this condition happens after an electrical storm, motor or control box may be damaged by lightning.</li><li>3. Resistance reading of the motor with lead wires disconnected from the control box can determine if trouble is in motor or control box.</li></ol>
Pump is noisy and pump rate is low.	<ol style="list-style-type: none"><li>1. Impeller may be partially clogged with some foreign objects causing noise and overload on the motor.</li></ol>
Grease and solids have accumulated around pump and will not pump out of basin.	<ol style="list-style-type: none"><li>1. Lower control switch may be set too high.</li><li>2. Run pump on Hand operation for several minutes with small amount of water running into basin to clean out solids and grease. This allows pump to break suction and surge which will break up the solids. If level switch is set properly this condition generally will not occur.</li><li>3. Trash and grease may have accumulated around floats causing pump to operate erratically.</li></ol>

**CAUTION – DISCONNECT ALL POWER AND CONTROL WIRES TO MOTOR AT CONTROL PANEL BEFORE STARTING DISASSEMBLY OPERATIONS. NEVER RELY ON OPENING CIRCUIT BREAKER ONLY.**

### SX50 DIMENSIONS

[Dimensions in mm]

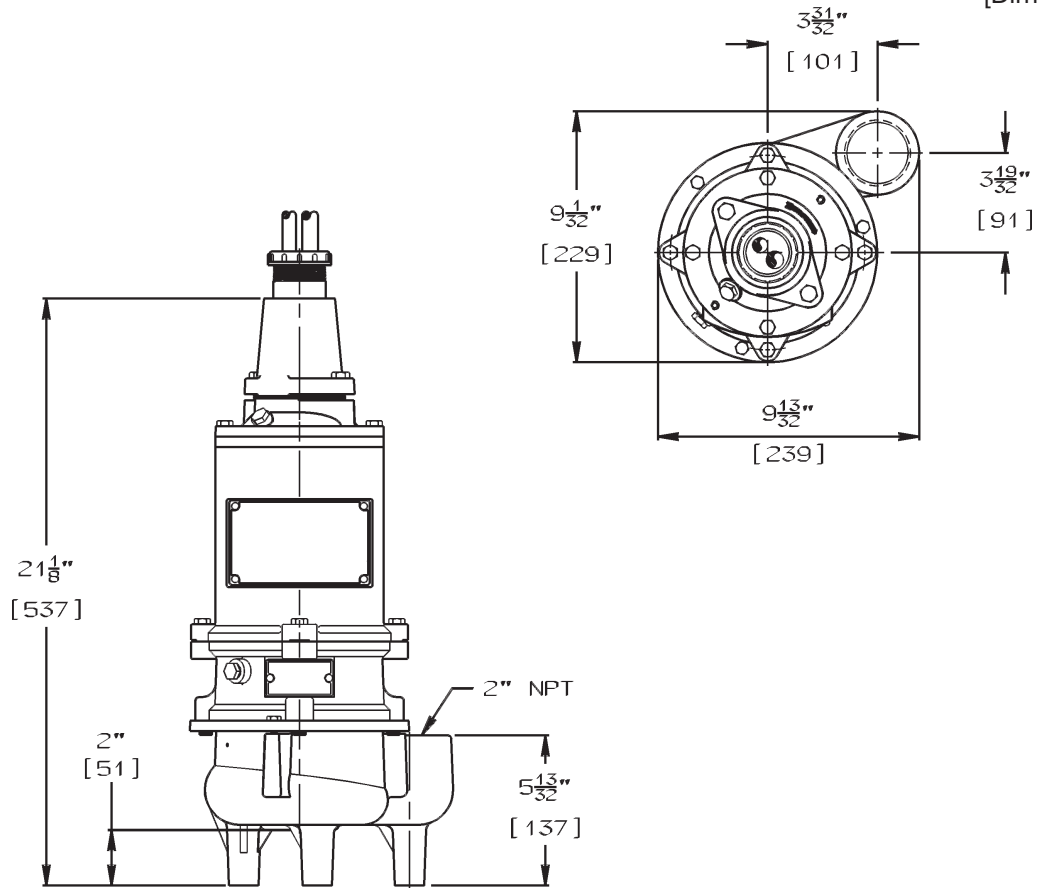

### SX50H, SX150H and SX200H DIMENSIONS

[Dimensions in mm]

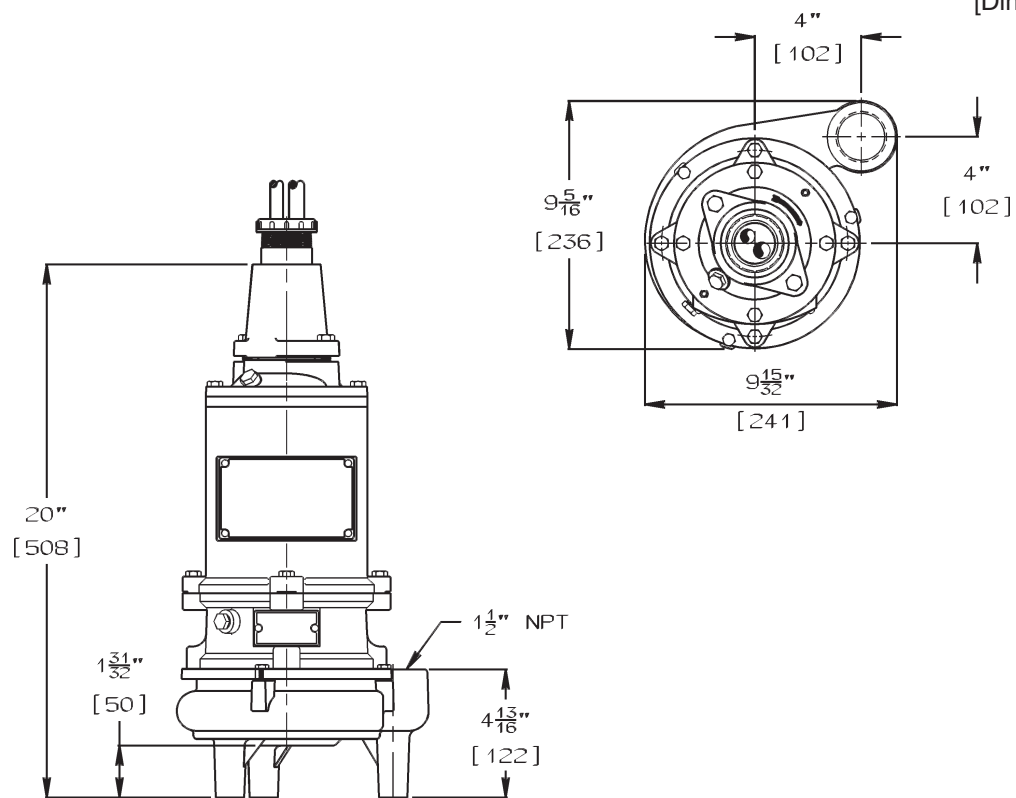

# SX50 PUMP PARTS

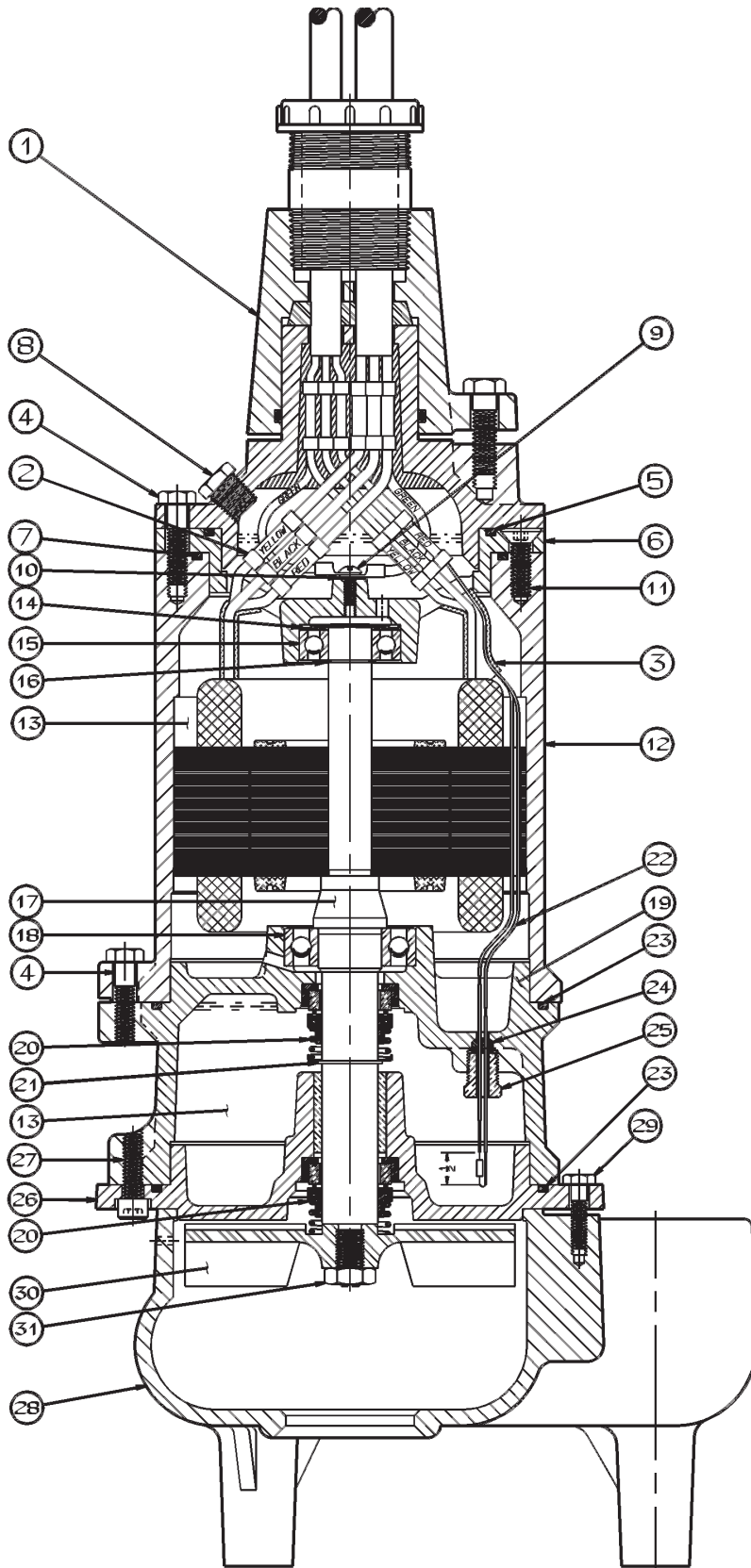

# SX50H PUMP PARTS

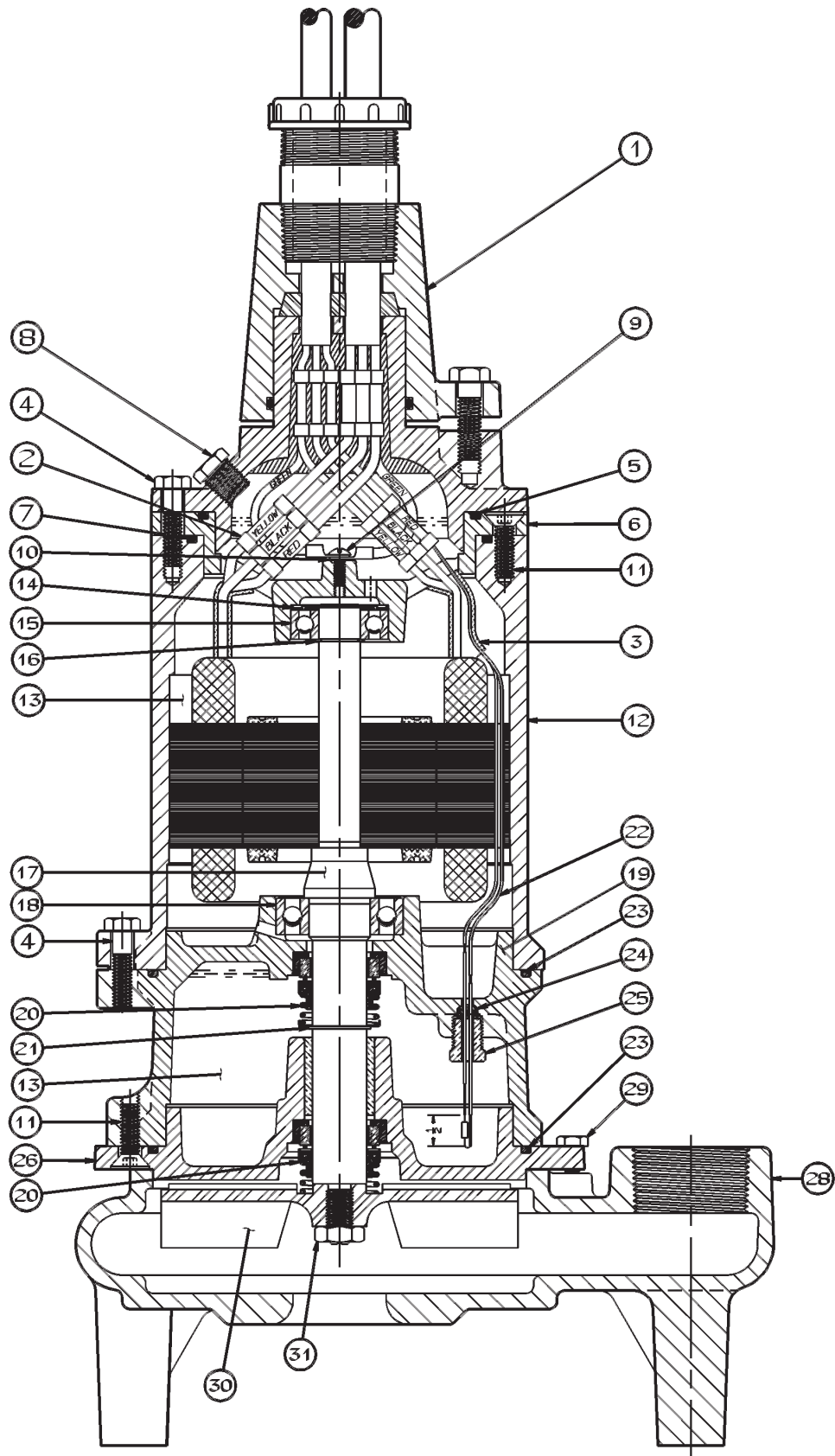



# SX150H and SX200H PUMP PARTS

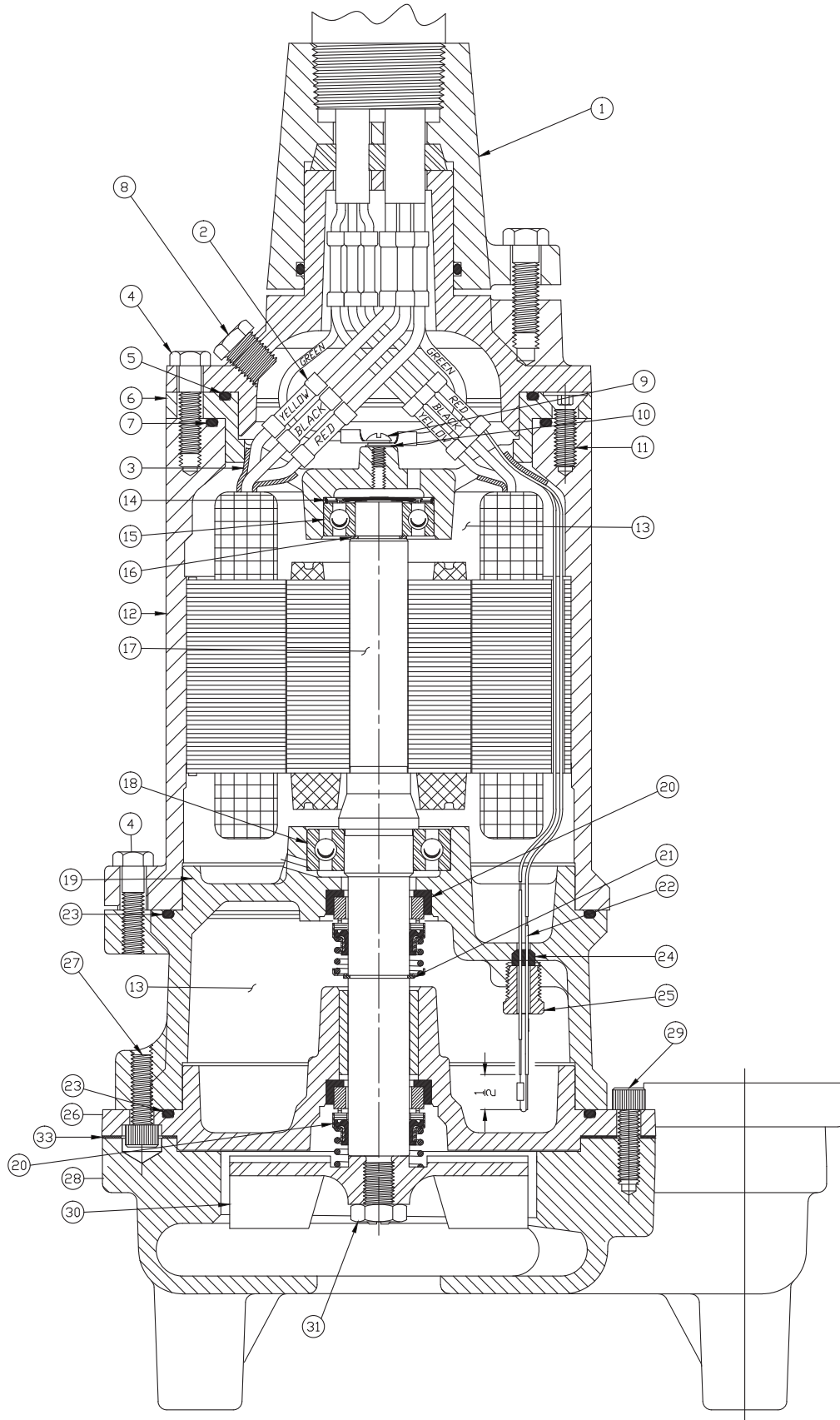



## SX SERIES PARTS LIST

Ref.	Description	Qty.	SX50	SX50H	SX150H/SX200H
1	CAP, CORD	1	22407C602	22407C602	22407C602
2	CONNECTOR	7	12762A001	12762A001	12762A001
3	TUBE, PLASTIC x 1-1/4" LG.	2	10649A102	10649A102	10649A102
4	SCREW, CAP 5/16 x 1-1/4" LG.	8	19100A012	19100A012	19100A012
5	O-RING, 4-1/2" x 4-1/4" x 1/8"	1	05876A122	05876A122	05876A122
6	CAP, UPPER BEARING	1	21570B100X	21570B100X	21570B100X
7	O-RING, 4-7/8" x 4-5/8" x 1/8"	1	05876A123	05876A123	05876A123
8	PLUG, PIPE 1/4" NPT	2	05022A054	05022A054	05022A054
9	SCREW, MACH. #10 x 1/2" LG.	1	05434A034	05434A034	05434A034
10	WASHER, LOCK	1	06107A015	06107A015	06107A015
11	SCREW, MACH. 5/16 x 1" LG. (SX50)	2	07597A017	-----	-----
11	SCREW, MACH. 5/15 x 1" LG. (SX50H)	6	-----	07597A017	07597A017
12	HOUSING W/STATOR (1Ø)	1	21571D150K	21571D150K	21571D120K
	HOUSING W/STATOR (3Ø) 230/460V	1	21571D152K	21571D152K	21571D130K
	HOUSING, MOTOR		21571D100X	21571D100X	21571D100X
	STATOR ONLY (1Ø)		21656C103	21656C103	21573C100
	STATOR ONLY (3Ø) 230/460V	1	21656C106	21656C106	21573C102
13	OIL, TRANSFORMER (1 GAL. CAN)	1.06 gal.	11009A008K	11009A008K	11009A008K
14	WASHER, SPRING	2	19331A005	19331A005	19331A005
15	BEARING, BALL (UPPER)	1	08565A013	08565A013	08565A013
16	RING, RETAINING	1	11816A006	11816A006	11816A006
17	ROTOR W/SHAFT (1Ø)	1	26859C101X	26859C101X	26859C106X
	ROTOR W/SHAFT (3Ø)	1	26859C104X	26859C104X	26859C104X
18	BEARING, BALL (LOWER)	1	08565A018	08565A018	08565A018
19	HOUSING, UPPER SEAL	1	21574D100X	21574D100X	21574D100X
20	SEAL, SHAFT	2	21576A010	21576A010	21576A010
21	RING, RETAINING	1	12558A006	12558A006	12558A006
22	ELECTRODE W/RESISTOR	1	22578A003	22578A003	22578A003
23	O-RING, 6-1/8" x 5-7/8" x 1/8"	2	05876A125	05876A125	05876A125
24	FERRULE, RUBBER	1	22579A000	22579A000	22579A000
25	PLUG, SPECIAL	1	21577A000	21577A000	21577A000
26	HOUSING, LOWER SEAL	1	21578C110X	21578C115X	21578C100X
27	SCREW, CAP 5/16 x 1" LG.	4	06106A008	-----	19100A037
28	CASE, VOLUTE	1	21612D000	26226D012	21580D1048
29	SCREW, CAP 1/4 x 1" LG.	3	19099A012	19099A012	19100A033
30	IMPELLER, RECESSED	1	21663C020	21663C010	21663C015 (SX150H) 21663C014 (SX200H)
31	NUT, JAM	1	19109A070	19109A070	19109A070
32	SCREW, SET	2	05013A027	05013A027	05013A027

# WIRING DIAGRAMS

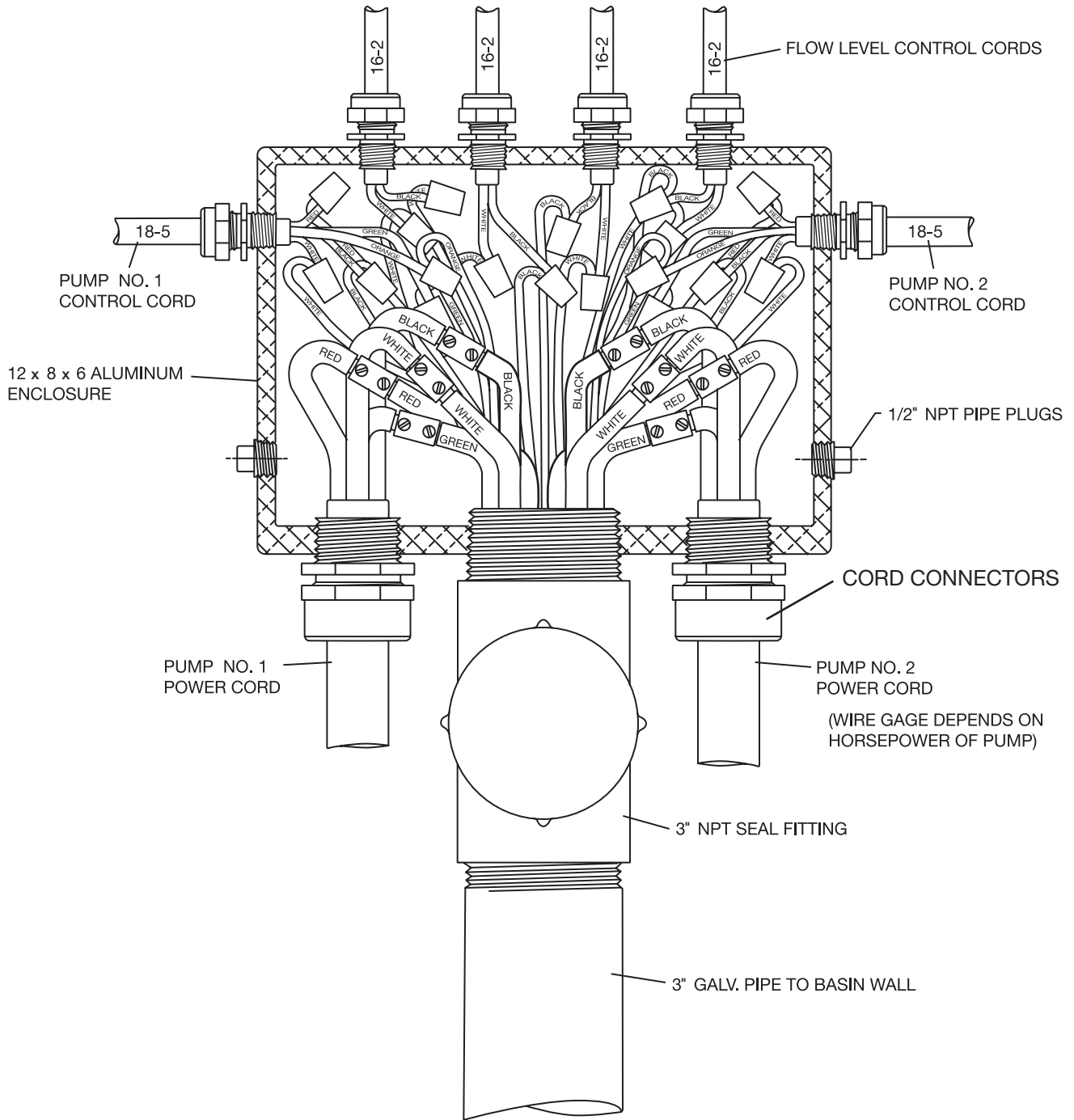

**NOTE:** All components shown must be approved for hazardous locations.

# WIRING SCHEMATIC FOR 230V, 1Ø SIMPLEX SYSTEM SX50/SX50H ONLY

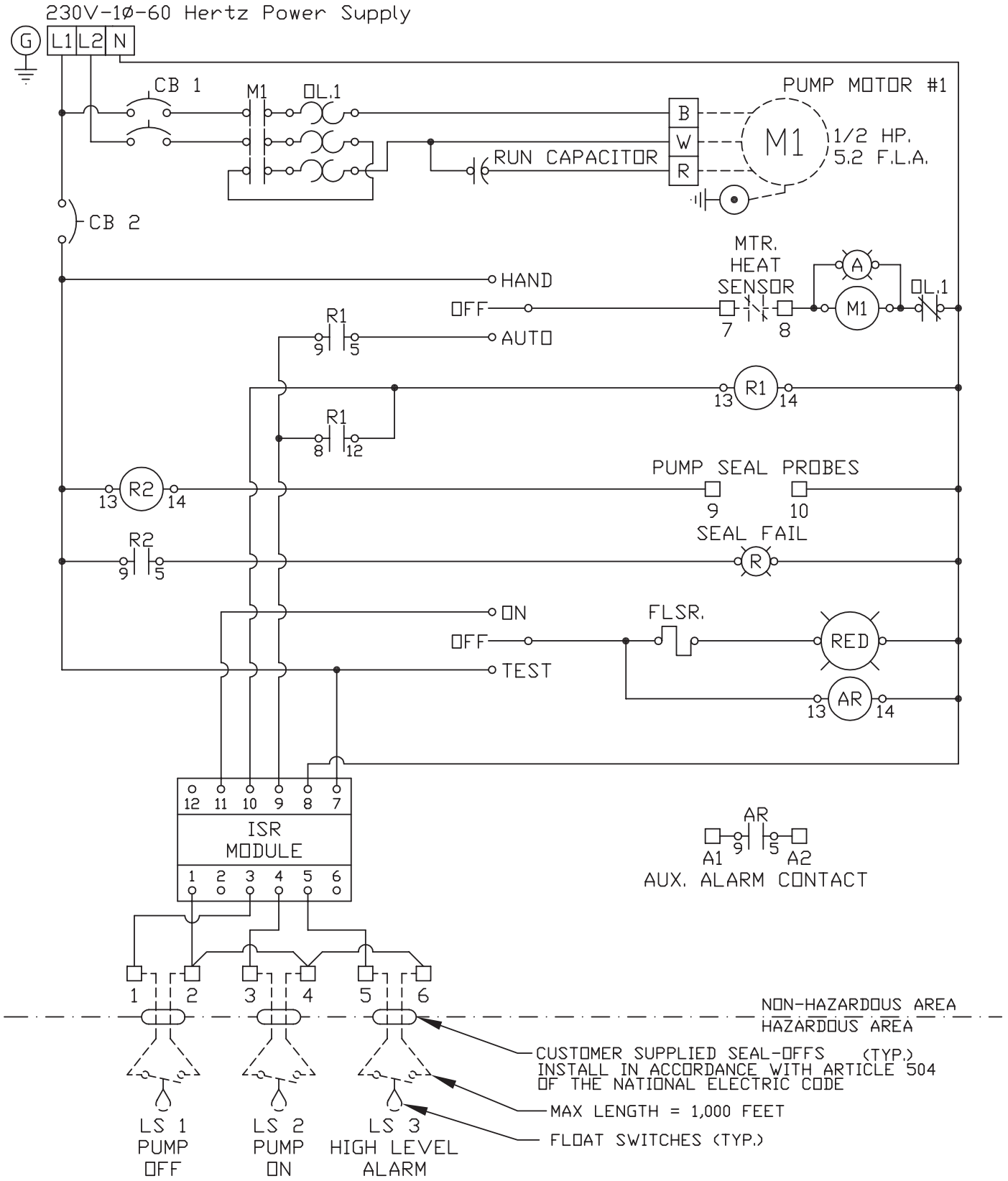

## WIRING DIAGRAM 230V, 1Ø

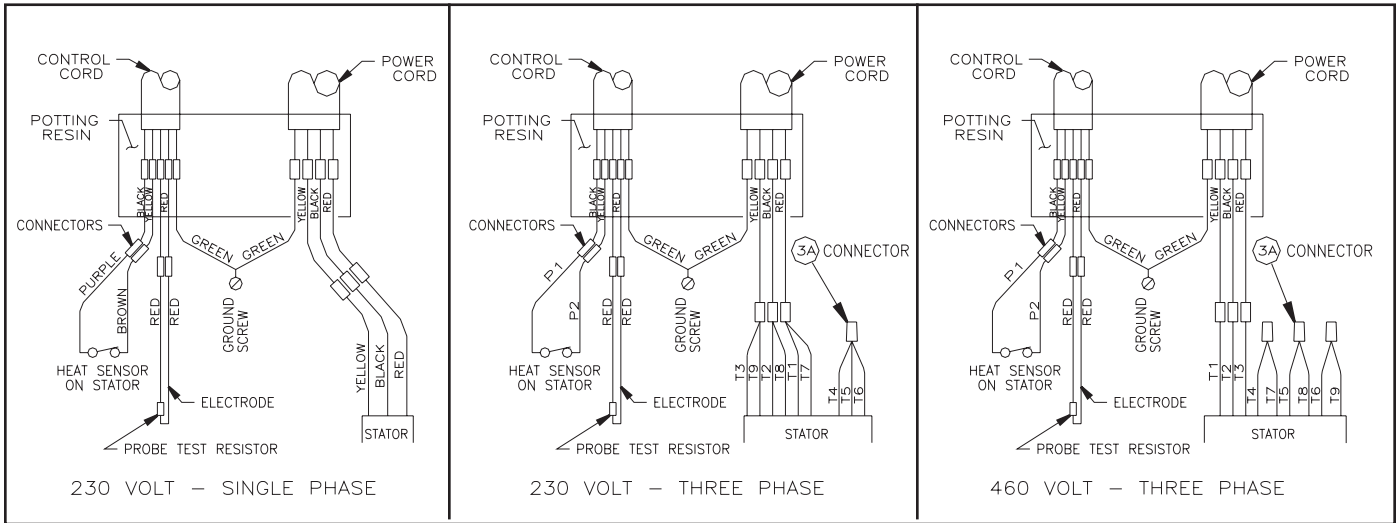

## WIRING SCHEMATIC FOR 230V, 3Ø DUPLEX SYSTEM

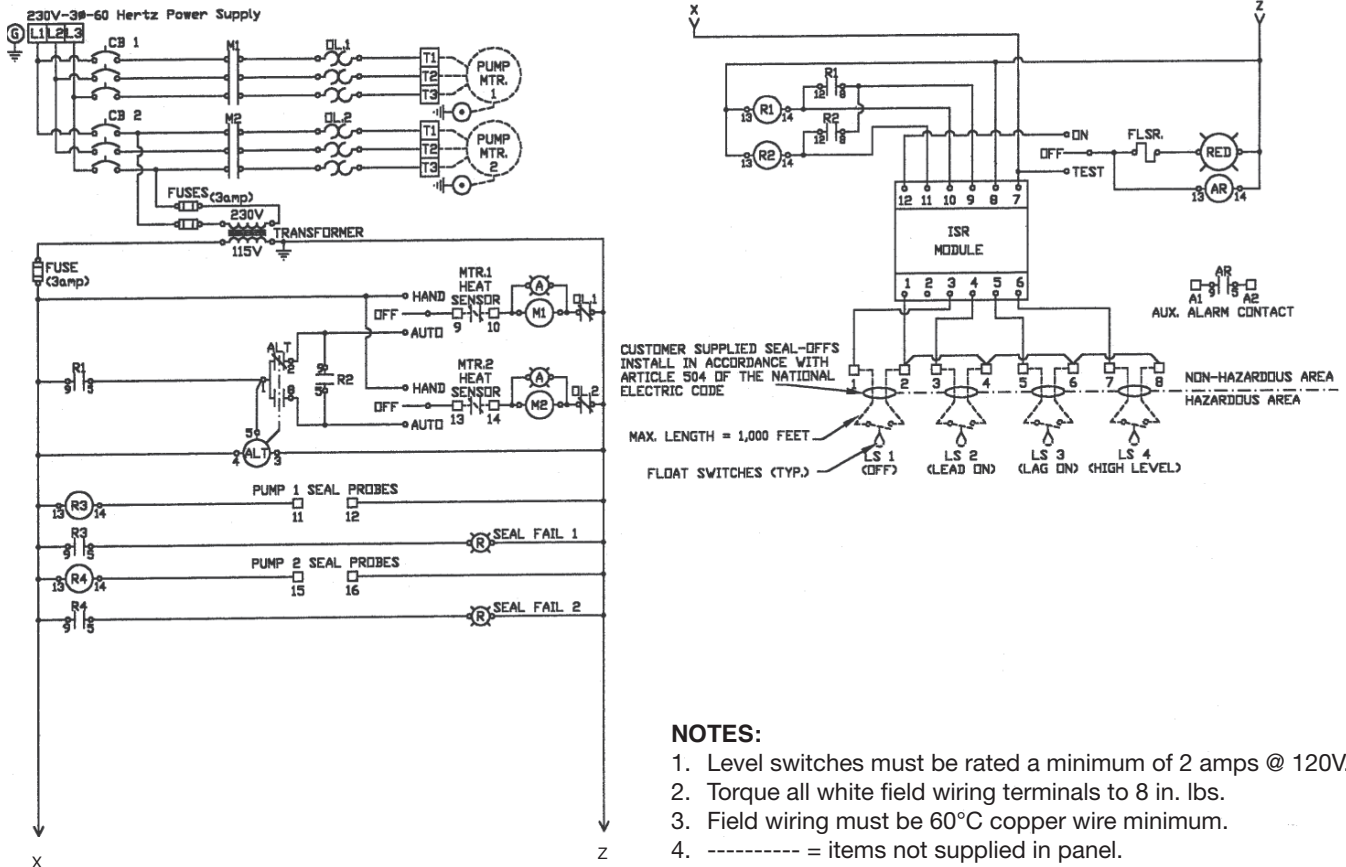

## WIRING SCHEMATIC FOR 230V, 3Ø SIMPLEX SYSTEM

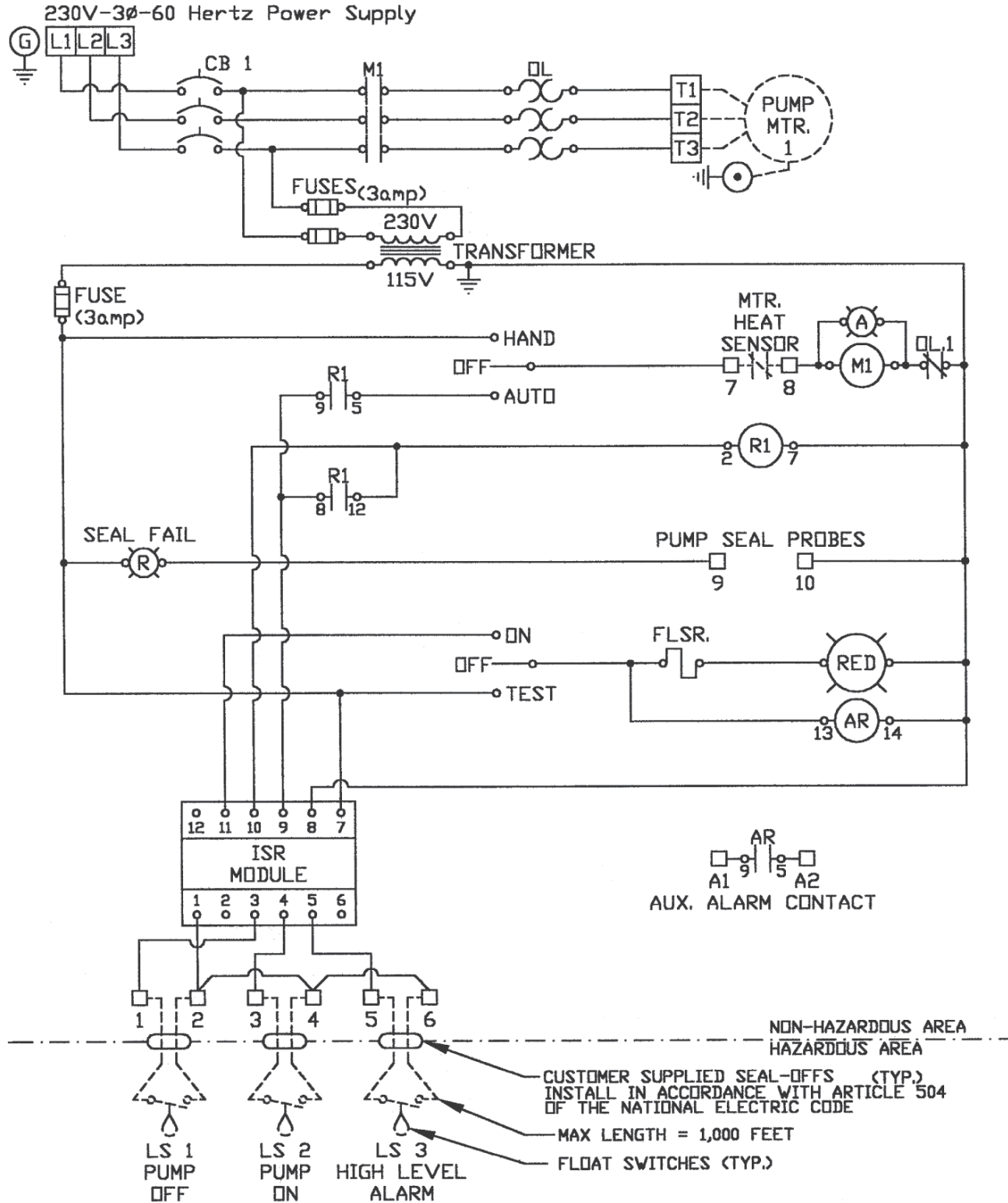

### NOTES:

1. Level switches must be rated a minimum of 2 amps @ 120V.
2. Torque all white field wiring terminals to 8 in. lbs.
3. Field wiring must be 60°C copper wire minimum.
4. ----- = items not supplied in panel.







## STANDARD LIMITED WARRANTY

Pentair Myers® warrants its products against defects in material and workmanship for a period of 12 months from the date of shipment from Pentair Myers or 18 months from the manufacturing date, whichever occurs first – provided that such products are used in compliance with the requirements of the Pentair Myers catalog and technical manuals for use in pumping raw sewage, municipal wastewater or similar, abrasive-free, noncorrosive liquids.

During the warranty period and subject to the conditions set forth, Pentair Myers, at its discretion, will repair or replace to the original user, the parts that prove defective in materials and workmanship. Pentair Myers reserves the right to change or improve its products or any portions thereof without being obligated to provide such a change or improvement for prior sold and/or shipped units.

Start-up reports and electrical schematics may be required to support warranty claims. Submit at the time of start-up through the Pentair Myers website: <http://forms.pentairliterature.com/startupform/startupform.asp?type=m>. Warranty is effective only if Pentair Myers authorized control panels are used. All seal fail and heat sensing devices must be hooked up, functional and monitored or this warranty will be void. Pentair Myers will cover only the lower seal and labor thereof for all dual seal pumps. Under no circumstance will Pentair Myers be responsible for the cost of field labor, travel expenses, rented equipment, removal/reinstallation costs or freight expenses to and from the factory or an authorized Pentair Myers service facility.

This limited warranty will not apply: (a) to defects or malfunctions resulting from failure to properly install, operate or maintain the unit in accordance with the printed instructions provided; (b) to failures resulting from abuse, accident or negligence; (c) to normal maintenance services and parts used in connection with such service; (d) to units that are not installed in accordance with applicable local codes, ordinances and good trade practices; (e) if the unit is moved from its original installation location; (f) if unit is used for purposes other than for what it is designed and manufactured; (g) to any unit that has been repaired or altered by anyone other than Pentair Myers or an authorized Pentair Myers service provider; (h) to any unit that has been repaired using non factory specified/OEM parts.

Warranty Exclusions: PENTAIR MYERS MAKES NO EXPRESS OR IMPLIED WARRANTIES THAT EXTEND BEYOND THE DESCRIPTION ON THE FACE HEREOF. PENTAIR MYERS SPECIFICALLY DISCLAIMS THE IMPLIED WARRANTIES OF MERCHANTABILITY AND FITNESS FOR ANY PARTICULAR PURPOSE.

Liability Limitation: IN NO EVENT SHALL PENTAIR MYERS BE LIABLE OR RESPONSIBLE FOR CONSEQUENTIAL, INCIDENTAL OR SPECIAL DAMAGES RESULTING FROM OR RELATED IN ANY MANNER TO ANY PENTAIR MYERS PRODUCT OR PARTS THEREOF. PERSONAL INJURY AND/OR PROPERTY DAMAGE MAY RESULT FROM IMPROPER INSTALLATION. PENTAIR MYERS DISCLAIMS ALL LIABILITY, INCLUDING LIABILITY UNDER THIS WARRANTY, FOR IMPROPER INSTALLATION. PENTAIR MYERS RECOMMENDS INSTALLATION BY PROFESSIONALS.

Some states do not permit some or all of the above warranty limitations or the exclusion or limitation of incidental or consequential damages and therefore such limitations may not apply to you. No warranties or representations at any time made by any representatives of Pentair Myers shall vary or expand the provision hereof.



### MYERS®

1101 MYERS PARKWAY  
ASHLAND, OHIO 44805  
PH: 855-274-8947  
WWW.FEMYERS.COM

490 PINEBUSH ROAD, UNIT 4  
CAMBRIDGE, ONTARIO, CANADA N1T 0A5  
PH: 800-363-7867  
WWW.FEMYERS.COM