

The SJE Level Monitor™ CL system is a convenient way to monitor tank levels by utilizing a scalable LED bargraph to represent the level as a percentage of a full tank. The adjustable alarm is easy to set using the alarm level and set buttons on the touch pad. As the liquid level reaches the installer-specified alarm setpoint, the audible alarm is activated. The alarm can be silenced using the test/silence button.

SJE LEVEL MONITOR™ FEATURES



- Input Power: 120 VAC, 50-60 Hz, 0.15A Class II transformer
- NEMA 1 rated for indoor use.
- Power on and alarm indicators.
- Adjustable alarm set point.
- Can be calibrated for tanks ranging:
 - 10" to 40" for 40" C-Level™ CL40
 - 25" to 100" for 100" C-Level™ CL100.
- Various cable lengths available to allow monitoring tanks up to 300ft away.
- Utilizes the floatless C-Level™ sensor.
- 10 segment LED bargraph displays the tank level.
- Test/Silence button
- Alarm Level button
- Set button
- Auxiliary contacts (normally open and normally closed) for Class II circuits.
- Can be configured as high level, low level or no alarm.

OPTIONS

This system is available with:

- C-Level™ CL40 sensor with 25' vented cable
- C-Level™ CL40 sensor with 50' vented cable
- C-Level™ CL40 sensor with 100' vented cable
- C-Level™ CL40 sensor with 200' vented cable
- C-Level™ CL40 sensor with 300' vented cable
- C-Level™ CL100 sensor with 25' vented cable
- C-Level™ CL100 sensor with 50' vented cable
- C-Level™ CL100 sensor with 100' vented cable
- C-Level™ CL100 sensor with 200' vented cable
- C-Level™ CL100 sensor with 300' vented cable

PREVENTATIVE MAINTENANCE

- Periodically inspect the product. Check that the vented cable has not been damaged so as to impair the performance of the product. Replace the product immediately if any damage is found or suspected.
- Use only SJE Rhombus® replacement parts.

⚠ WARNING**ELECTRICAL SHOCK HAZARD**

Disconnect power before installing or servicing this product. A qualified service person must install and service this product according to applicable electrical and plumbing codes.

⚠ WARNING**EXPLOSION OR FIRE HAZARD**

Do not use this product with flammable liquids. Do not install in hazardous locations as defined by National Electrical Code, ANSI/NFPA 70.

Failure to follow these precautions could result in serious injury or death. Replace product immediately if switch cable becomes damaged or severed. Keep these instructions with warranty after installation. This product must be installed in accordance with National Electric Code, ANSI/NFPA 70 so as to prevent moisture from entering or accumulating within boxes, conduit bodies, fittings, float housing, or cable.

For detailed specifications on this product, or for the complete line of SJE Rhombus® panel, alarm, and switch products, visit our web site at www.sjrhombus.com.

INSTALLING THE C-LEVEL™ SENSOR and SJE LEVEL MONITOR™ CL

Caution: The C-Level™ sensor cable needs to run in separate conduit from the pump and power lines. Operating temperature for the C-Level™ sensor is 32°F (0°C) to 120°F (50°C).

- Determine the normal operating levels for the configuration as shown in **Figure A**.
- Position the C-Level™ sensor at the appropriate location on the pipe and secure the sensor as shown in **Figure D**. **Warning: Do not support the C-Level™ sensor by the cable. Position the sensor in the tank so that nothing is pushing on the diaphragm.**
- Tighten all hose clamps using a screw driver. Over-tightening may result in damage to the plastic parts. **Note:** All hose clamp components are made of 18-8 stainless steel material. See your SJE Rhombus® supplier for replacement parts.
- Mount the SJE Level Monitor™ CL in desired location.
- If using auxiliary contacts, connect wire to terminal block as shown in **Figure B**. **ELECTRICAL SHOCK WARNING: Auxiliary contacts are designed for Class II circuit. Only use load meeting Class II circuit requirements.**
- Calibrate SJE Level Monitor™ CL to desired range. See section "Calibrating the Monitor to a Specific Tank" for instructions on how to calibrate.
- Set alarm mode and level as desired. See sections "Alarm Set Points Mode" for instructions.
- Functionally test system by filling the tank and witnessing proper operation.

Figure A

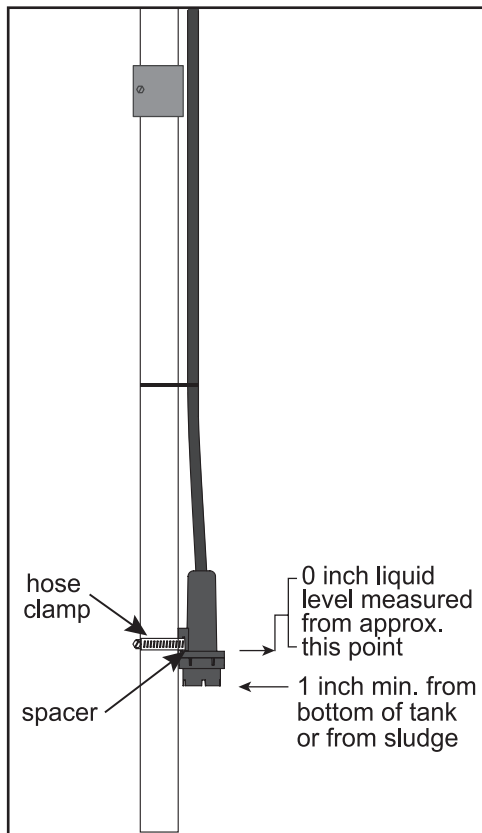
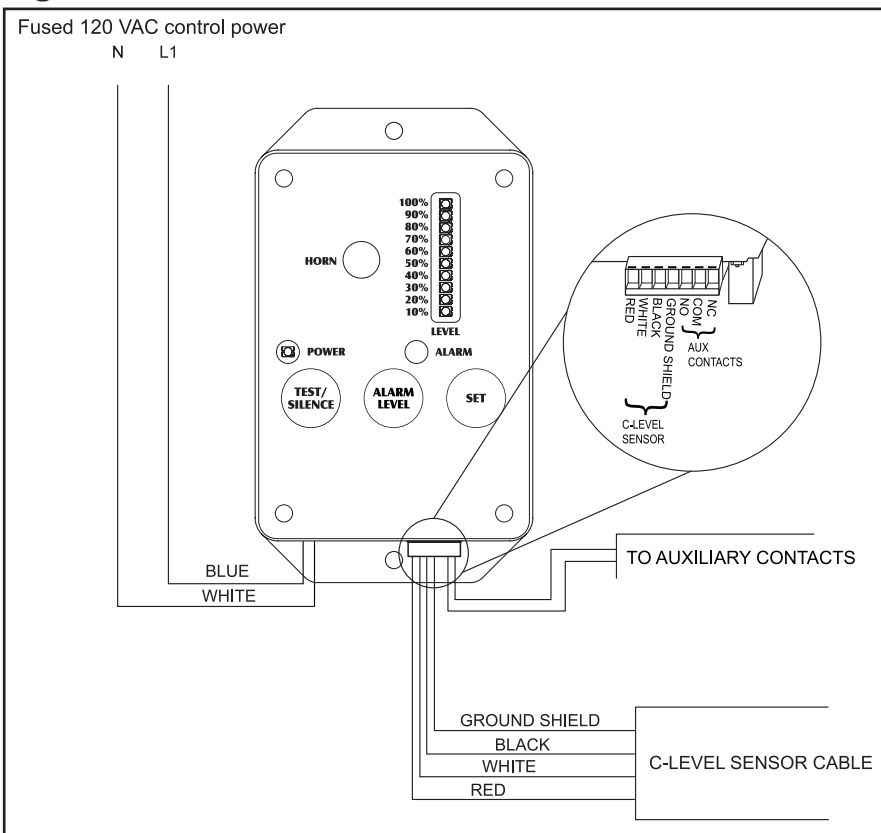

Figure B



CALIBRATING THE MONITOR TO A SPECIFIC TANK

1. Enter calibration mode by pressing and holding the "Alarm Level" and "Test/Silence" buttons for approximately 5 seconds or until the power LED light starts to blink as shown in **Figure C**.
Note: While in the calibration mode, the power light will continue blinking.
2. Bar graph will now display current tank set level by lighting up one LED. This is indicated with a percent from 10%-100%. See **Table 1** for available monitoring levels.
3. To change the SJE Level Monitor™ CL monitoring level, push the "Set" button. This will toggle the light bar up one position.
4. After desired monitoring level is lit, wait 10 seconds and the SJE Level Monitor™ CL will return to normal operating mode.
Note: During calibration mode, if at any time a button is not pushed within 10 seconds the unit will return to normal operating mode.
5. Functionally test system each time calibration is changed to insure system is operating as expected.

Figure C

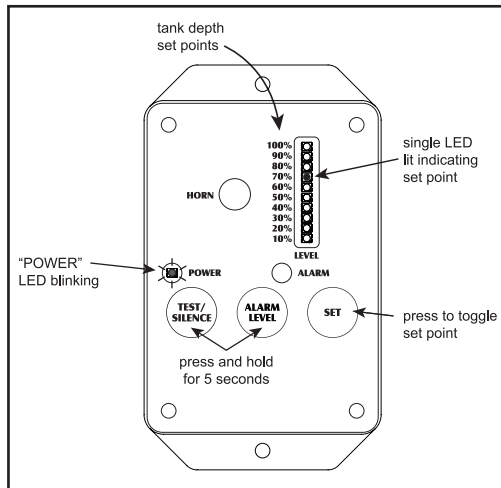

Table 1

For Tank Depths (English) 40 inch C-Level™	For Tank Depths (English) 100 inch C-Level™	Choose this depth bar
10 to 12 inches	25 to 30 inches	10%
13 to 15 inches	31 to 37 inches	20%
16 to 18 inches	38 to 45 inches	30%
19 to 21 inches	46 to 52 inches	40%
22 to 24 inches	53 to 60 inches	50%
25 to 27 inches	61 to 67 inches	60%
28 to 30 inches	68 to 75 inches	70%
31 to 33 inches	76 to 82 inches	80%
34 to 36 inches	83 to 90 inches	90%
37 to 40 inches	91 to 100 inches	100%

ALARM SET POINTS MODE

SETTING THE MONITOR TO A HIGH LEVEL OR LOW LEVEL ALARM

The monitor can be set to be a **high water** or **low water** alarm. When set for high water, the alarm will activate when the liquid level rises above the set point. When set as a **low water** alarm, the alarm will activate when the liquid level falls below the set point. The default configuration for the alarm is for **high water** alarm.

To change the configuration to perform the following steps:

1. Disconnect power to the SJE Level Monitor™ CL and any product connected to auxiliary contacts as shown in **Figure D** on next page.
2. Disconnect terminal block.
3. Remove four corner screws on the front cover.
4. Turn cover over to view the back as shown in **Figure E** on next page. Move jumper of J3 from pin 1 and pin 2 for **high level** alarm to pin 2 and pin 3 for **low level** alarm.
5. Reassemble alarm and reconnect terminal block.
6. Connect power and test alarm to ensure system operates properly.

SET AND CHECK THE ALARM LEVEL

To view the current alarm level press and hold the "Alarm Level" button as shown in **Figure F** on next page. The display will switch to single lit LED on the bar graph. The LED will be set to a percentage of total tank range set in calibration mode. **If all LED bars are lit when the "Alarm Level" button is pushed the alarm is set to "Disable" mode which will disable the audible alarm, alarm LED, and auxiliary contacts.**

To change the alarm set point:

1. Enter alarm set point mode by pressing and holding the "Alarm Level" button for approximately 5 seconds or until the power LED light starts to blink as shown in **Figure C**.
Note: While in the alarm set point mode, the power light will continue blinking.
2. Bar graph will now display current tank set level by lighting up one LED. This is indicated with a percent from 10%-100%. All LED lights will indicate alarm is deactivated.

- To change the SJE Level Monitor™ CL monitoring level, push the "Set" button. This will toggle the light bar up one position.
- After desired monitoring level is lit, wait 10 seconds and the SJE Level Monitor™ CL will return to normal operating mode.
Note: During alarm set point mode, if at any time a button is not pushed within 10 seconds the unit will return to normal operating mode.
- Functionally test system each time alarm is set to insure system is operating as expected.

Figure D

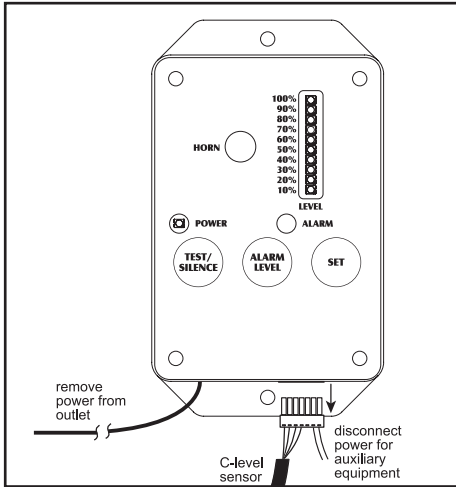

Figure E

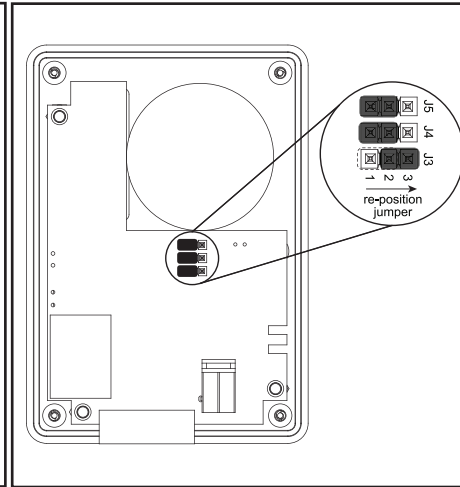
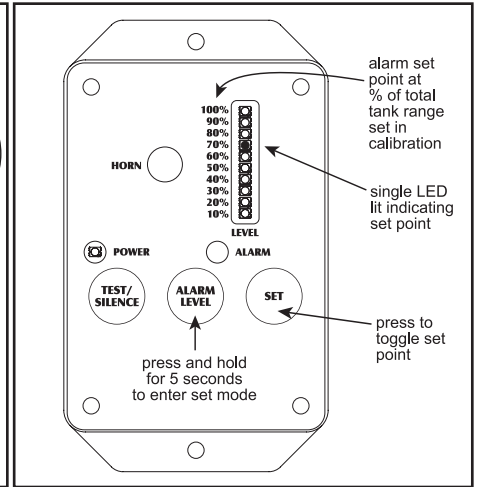

Figure F



SILENCING THE SJE LEVEL MONITOR™ CL

The SJE Level Monitor™ CL has two alarm modes available: **Temporary Silence Mode** and **Complete Silence Mode**

Temporary Silence Mode will silence an active alarm. When pressing the "Silence/Test" button during an active alarm the unit will silence the audible alarm but will still leave the auxiliary contacts and LED activated. When the liquid level falls out of alarm level for 5 seconds, the audible alarm will reset.

Complete Silence Mode disables the audible alarm of the monitor but will still leave the auxiliary contacts and alarm LED enabled. When the monitor is set up in this mode, when the alarm level is reached, contacts will activate and the LED will light up but no audible alarm will be active. To set the monitor in **Complete Silence Mode** perform the following steps:

- Disconnect power to the SJE Level Monitor™ CL and any product connected to auxiliary contacts as shown in **Figure G**.
- Disconnect terminal block.
- Remove four corner screws on the front cover.
- Turn cover over to view the back as shown in **Figure H**. Move jumper of J5 from pin 1 and pin 2 for audible alarm mode to pin 2 and pin 3 for complete silence mode.
- Reassemble alarm and reconnect terminal block.
- Connect power and test alarm to ensure system operates properly.

The alarm can also be disabled. See "SET AND CHECK THE ALARM LEVEL" section under "Alarm Set Points Mode". When alarm is disabled, the monitor will not activate the audible alarm, alarm LED, or auxiliary contacts.

Figure G

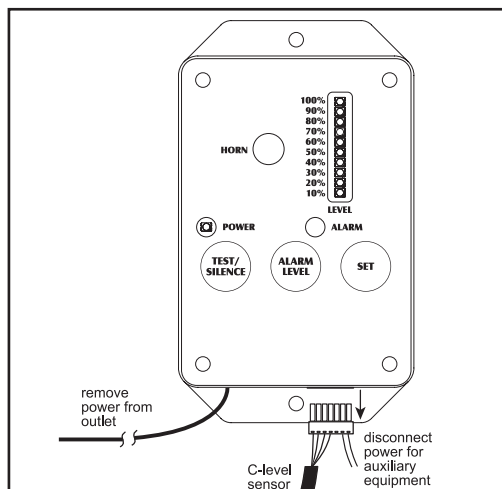
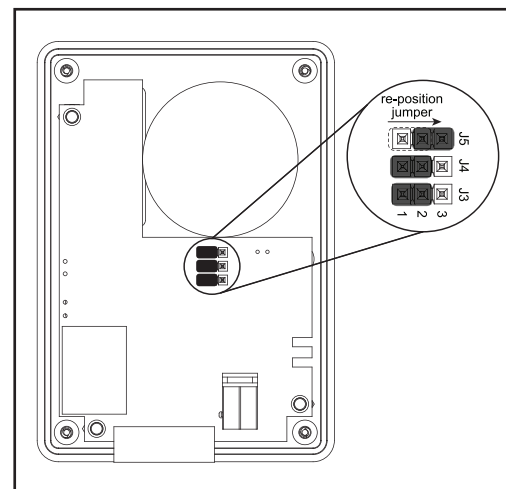

Figure H



TESTING THE SJE LEVEL MONITOR™ CL

The SJE Level Monitor™ CL alarm can be tested by pressing the "Test/Silence" button. This can only be done when the unit is not in alarm mode. The "Test/Silence" button will activate the audible alarm, alarm LED light, and auxiliary contacts.

Note: "Test" button only test to insure the audible alarm, visual alarm, and auxiliary contacts are working. "Test/Silence" button does not test set points. To test set points, fill and empty the tank to insure proper operations.

TROUBLESHOOTING THE C-LEVEL™ SENSOR

1. Verify that the vented cable is not kinked or has any holes in it. If either condition exists, the pressure sensor may fail or give inaccurate level readings.
2. Vent must be in a dry environment and unobstructed. This is required to compensate for barometric pressure changes. Obstructing the vent will result in inaccurate level readings.
3. The black diaphragm is located on the end of the sensor body. The diaphragm must not be damaged or deformed. A damaged or deformed diaphragm will result in inaccurate level readings.
4. Verify the bottom of the C-Level™ sensor is not resting on the bottom of the tank or on any other obstacle.
5. Verify that the electrical cable is not damaged or severed.
6. Verify that the shielding for cable is properly connected to the terminal block.
7. Verify that the C-Level™ sensor is properly connected to the terminal block.

SJE RHOMBUS® LIMITED WARRANTY

SJE Rhombus offers a five-year limited warranty on the SJE Level Monitor™ and a two-year limited warranty on the C-Level™ Sensor. For complete terms and conditions, please visit www.sjerhombus.com.

NOTICE!

Products returned must be cleaned, sanitized, or decontaminated as necessary prior to shipment to ensure that employees will not be exposed to health hazards in handling said material. All applicable laws and regulations shall apply.

Notes: _____

Horizontal lines for notes



Technical Support: +1 800-746-6287
techsupport@sjerhombus.com
www.sjerhombus.com

Technical Support Hours: Monday-Friday, 7 A.M. to 6 P.M. Central Time

PN 1036888F 08/23
© 2021 SJE, Inc. All Rights Reserved.
SJE Rhombus is a trademark of SJE, Inc.