



# TANK ALERT® I Alarm Installation Instructions

This alarm system monitors liquid levels in lift pump chambers, sump pump basins, holding tanks, sewage, agricultural, and other non-potable water applications.

The Tank Alert® I indoor alarm system can serve as a high or low level alarm depending on the float switch model used. The alarm horn sounds when a potentially threatening liquid level condition occurs. The horn can be turned off, but the warning light remains on until the condition is remedied. A green "power on" light indicates power to the alarm panel.

## TANK ALERT® I ALARM



- **120 VAC Model Voltage** - (circuits not supervised) Primary: 120 VAC, 50/60 Hz, 5 watts maximum (alarm condition) Secondary: 12 VAC
- **230 VAC Model Voltage** - (circuits not supervised) Primary: 230 VAC, 50/60 Hz, 5 watts maximum (alarm condition) Secondary: 12 VAC
- NEMA 1 enclosure rated for indoor use.
- Red warning light, green "power on" light, alarm test switch, and horn silence switch.
- Alarm horn sounds at 86 decibels at 10 feet (3 meters).
- 6 foot (1.8 meter) power cord.
- Can be used with any switching mechanism rated to include 1 amp, 12 VAC load.
- Maximum line impedance for initiating device: 5 ohms.
- Alarm system (when installed on separate circuit) operates even if the pump circuit fails.
- Complete package includes standard Sensor Float® control switch with 15 feet (4.57 meters) of cable (other lengths available) and mounting clamp.
- Switching mechanism operates on low voltage and is isolated from the power line to reduce the possibility of shock.
- Three-year limited warranty.

## OPTIONS

When ordered with the alarm, this system is available with:

- alternate float switch models for high or low level warning.
- 120 VAC primary voltage or 230 VAC primary voltage.
- splice kit.

### PREVENTATIVE MAINTENANCE

- Periodically inspect the product. Check that the cable has not become worn or that the housing has not been damaged so as to impair the protection of the product. Replace the product immediately if any damage is found or suspected.
- Periodically check to see that the float is free to move and operate the switch.
- Use only SJE-Rhombus® replacement parts.

## SJE-RHOMBUS® THREE-YEAR LIMITED WARRANTY

SJE-RHOMBUS® warrants to the original consumer that this product shall be free of manufacturing defects for three years after the date of consumer purchase. During that time period and subject to the conditions set forth below, SJE-RHOMBUS® will repair or replace, for the original consumer, any component which proves to be defective due to defective materials or workmanship of SJE-RHOMBUS®.

**THIS EXPRESS WARRANTY DOES NOT APPLY TO THE MOTOR START KIT COMPONENT. SJE-RHOMBUS® MAKES NO WARRANTIES OF ANY TYPE WITH RESPECT TO THE MOTOR START KIT.**

**ELECTRICAL WIRING AND SERVICING OF THIS PRODUCT MUST BE PERFORMED BY A LICENSED ELECTRICIAN.**

**THIS WARRANTY DOES NOT APPLY:** (A) to damage due to lightning or conditions beyond the control of SJE-RHOMBUS®, (B) to defects or malfunctions resulting from failure to properly install, operate or maintain the unit in accordance with printed instructions provided; (C) to failures resulting from abuse, misuse, accident, or negligence; (D) to units which are not installed in accordance with applicable local codes,

ordinances, or accepted trade practices, and (E) to units repaired and/or modified without prior authorization from SJE-RHOMBUS®.

*Some states do not allow limitations on how long an implied warranty lasts, so the above limitation may not apply to you. Some states do not allow the exclusion or limitation of incidental or consequential damages, so the above limitation or exclusion may not apply to you. This warranty gives you specific legal rights, and you may also have other rights which vary from state to state.*

**TO OBTAIN WARRANTY SERVICE:** The consumer shall assume all responsibility and expense for removal, reinstallation, and freight. Any item to be repaired or replaced under this warranty must be returned to SJE-RHOMBUS®, or such place as designated by SJE-RHOMBUS®.

**ANY IMPLIED WARRANTIES OF MERCHANTABILITY OR FITNESS ARE LIMITED TO THE DURATION OF THIS WRITTEN WARRANTY. SJE-RHOMBUS® SHALL NOT, IN ANY MANNER, BE LIABLE FOR ANY INCIDENTAL OR CONSEQUENTIAL DAMAGES AS A RESULT OF A BREACH OF THIS WRITTEN WARRANTY OR ANY IMPLIED WARRANTY.**

**WARNING****ELECTRICAL SHOCK HAZARD**

Disconnect power before installing or servicing this product. A qualified service person must install and service this product according to applicable electrical and plumbing codes.

**WARNING****EXPLOSION OR FIRE HAZARD**

Do not use this product with flammable liquids. Do not install in hazardous locations as defined by National Electrical Code, ANSI/NFPA 70.



Failure to follow these precautions could result in serious injury or death. Replace product immediately if switch cable becomes damaged or severed. Keep these instructions with warranty after installation. This product must be installed in accordance with National Electric Code, ANSI/NFPA 70 so as to prevent moisture from entering or accumulating within boxes, conduit bodies, fittings, float housing, or cable.

*For detailed specifications on this product, or for the complete line of SJE-Rhombus® panel, alarm, and switch products, visit our web-site at [www.sjerrhombus.com](http://www.sjerrhombus.com).*

**INSTALLING THE ALARM & FLOAT SWITCH**

1. Determine indoor mounting location for alarm panel.
2. Insert screw (supplied) at desired wall location.  
**Note:** Screw is to be located over wall stud or used with a wall anchor sized for a #8 x 1.25 self tapping screw.
3. Make sure power to alarm panel is disconnected.
4. Hang alarm panel using keyhole on panel back. Install second screw between tabs located on bottom of panel.
5. Mount the cord by placing the cord into the clamp as shown in Figure A.
6. Locate the clamp at the desired activation level and secure the clamp to the discharge pipe as shown in Figure A. **Note:** Do not install cord under hose clamp.
7. Tighten the hose clamp using a screwdriver. Over tightening may result in damage to the plastic clamp. Make sure the float cable is not allowed to touch the excess hose clamp band during operation.
8. Bring cable leads back to alarm device and wire according to Figure B.  
**Note:** All hose clamp components are made of 18-8 stainless steel material. See your SJE-Rhombus® supplier for replacements.  
**Note:** When used with a pump application, connect alarm to a circuit separate from the pump circuit. This allows the alarm to operate if the pump circuit fails.
9. Plug the panel in to apply power. The green "power on" light should come on.
10. Check installation by manually tipping the float. The horn and warning light should come on.
11. Move the horn silence switch to silence, the horn should silence while the red light stays on.
12. **You must manually reset alarm after activation.** Push horn button back to horn position and press "push to test" button. The light and horn should activate.
13. Test unit once per week to ensure proper operation.
14. Using the provided cable clasp, secure cord to outlet as shown in Figure C. Use existing receptacle faceplate screw and supplied washer.

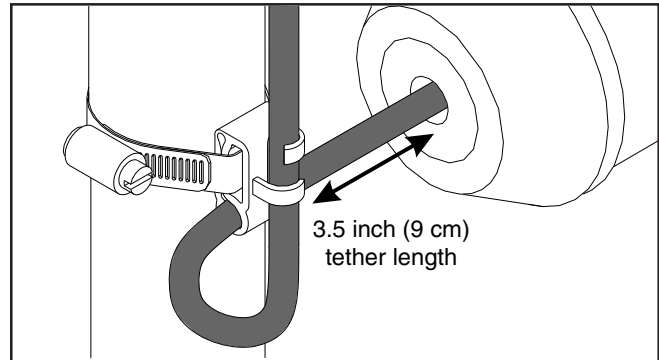
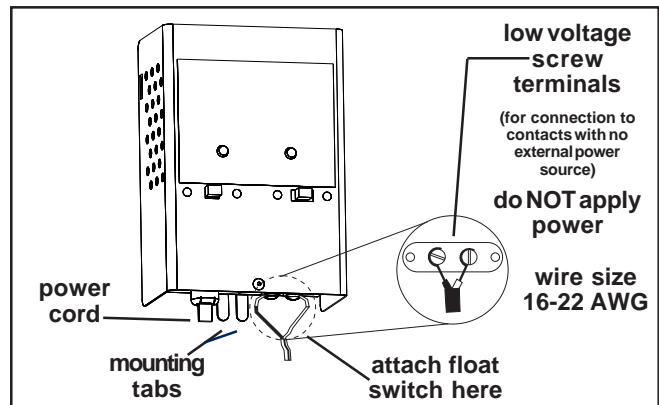
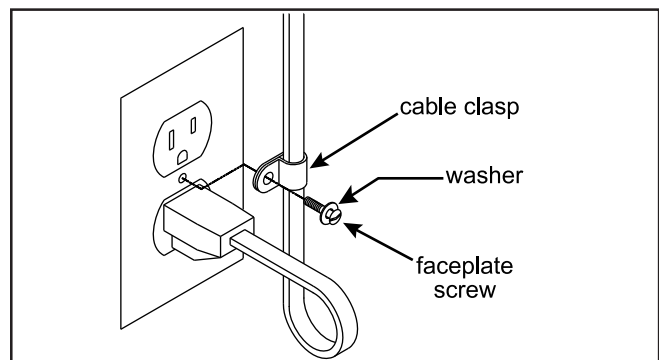
**Figure A****Figure B****Figure C**

# SJE-Rhombus®

22650 County Highway 6 ■ P.O. Box 1708 ■ Detroit Lakes, Minnesota 56502 USA  
1-888-DIAL-SJE (1-888-342-5753) ■ Phone: 218-847-1317 ■ Fax: 218-847-4617 ■ E-mail: [sje@sjerrhombus.com](mailto:sje@sjerrhombus.com)

Instl. Instr. PN 1011978G  
©SJE-Rhombus Model TA101 04/08